

Aarbergerweg 9  
1435 CA Rijsenhout  
P.O. Box 255  
1430 AG Aalsmeer  
The Netherlands  
Tel. +31 (0)297 219100  
www.zantingh.com  
info@zantingh.com



**ZANTINGH**



## MOUNTING INSTRUCTIONS



## ZANTINGH BURNERINSTALLATIONS



YOU CAN COUNT ON OUR EXPERTISE



Dear Customer,

We would like to thank you for purchasing our product.

We provide this manual to ensure the distribution of all important information for your safety, optimal profit and product lifetime.

Please read the instructions carefully before installing or operating the product.

The safety and instructions in this manual must be followed to ensure that installation, commissioning, operation and maintenance are safe and in accordance to (local) standards and regulations.

Our technical department can provide additional information and support.

If you have any questions, please contact us.

**Phone general:** +31(0)297 – 219 100

**Phone service:** +31(0)297 – 219 125

+31(0)20 – 48 58 212 (*outside of office hours*)

**E-mail:** [info@zantingh.com](mailto:info@zantingh.com)

## **CONTENTS**

	page
<b>1. INTRODUCTION</b>	<b>7</b>
<b>2. DANGERS, WARNINGS AND NOTES OF CAUTION</b>	<b>8</b>
<b>3. TECHNICAL SPECIFICATIONS</b>	<b>11</b>
3.1 Key to the model name:	11
3.2 Datasheet	12
<b>4. PRODUCT SPECIFICATION</b>	<b>13</b>
4.1 Burner component	13
4.2 Air fan component	13
4.3 Gas train	14
4.4 Oil supply	14
4.5 Control panel	14
<b>5. ASSEMBLY</b>	<b>16</b>
5.1 Mounting the burner on the boiler	16
5.1.1 Brickwork	17
5.2 Air fan connection	18
5.2.1 Mounting the air fan of a TR burner installation	18
5.2.2 Mounting the air fan in an RKB burner installation.	19
5.2.3 Air fan with an additional air duct	20
5.3 Mounting the gas train	21
5.3.1 Main gas supply connection	21
5.3.2 Pilot gas connection	22
5.3.3 Relief lines	22
5.3.4 Measuring lines (only Autoflame)	22
5.4 Oil supply connection	23
5.4.1 Oil pump installation	24
5.4.2 Oil buffer system	25
<b>6. ELECTRICAL CONNECTION</b>	<b>26</b>
6.1 Connecting a Siemens LMV26 controlled TR burner	26
6.1.1 Connecting the burner to the switch panel	26
6.1.2 Connecting the gas train	26
6.1.3 Connecting the air fan motor and frequency drive	26
6.2 Connecting a Siemens LMV26 controlled RKB compact burner	27
6.2.1 Connecting the gas train components	27
6.2.2 Connecting the air fan motor and frequency drive	27
6.3 Connecting a Siemens LMV5 controlled RKB burner	27
6.3.1 General instructions for EMC cables	28
6.3.2 Connecting the burner terminal box	28

6.3.3 Connecting the gas train terminal box	28
6.3.4 Connecting the servo motors	28
6.3.5 Connecting the air fan motor and frequency drive	29
6.3.6 Connecting the UV cell	30
6.4 Burner load control	30
6.5 Oil pump to switch panel connection	30
6.6 Boiler safeties	31
6.6.1 Low water device	31
6.6.2 Maximal thermostat	31
6.7 Fiduface connections to the climate computer	31
<b>7. PUTTING INTO OPERATION</b>	<b>33</b>
<b>8. WARRANTY CONDITIONS</b>	<b>34</b>
<b>ANNEX</b>	<b>35</b>
1. Lay out and location of parts	35
2. List of cables	36
3. Plug-In terminal instruction	37
4. EMC gland instruction	38
5. Cable and gland sizes for air fan motor	39
6. Cable and gland sizes for oil pump motor	41
7. Low water device SYR 2"	42



## 1. INTRODUCTION



### **IMPORTANT read this first!**

The instructions are an integral part of the product. The instructions contain important information on the commissioning, usage and operation of the product. Please read the instructions carefully.

The guarantee becomes null and void if the mounting instructions are not followed. Zantingh B.V. cannot be held liable for these damages.

Store this manual carefully near the system!

A burner system is a combination of:

- **Electrical engineering**
- **Gas engineering**
- **Central heating engineering**
- **Measurement and control engineering**

A certified heating or electrical installer should instal the product, in accordance with the applicable (local) standards and regulations.

In Europe the applicable requirements are specified in:

- EN 676: general requierments for the construction and operation of gas burner systems;
- NEN 1010: electrical installations for low-voltage;
- NEN 1078: requirements for gas installations  $\leq 500$ mbar;
- NEN 2078: requirements for industrial gas installations;
- NEN 3028: requirements for fuel combustion installations;
- As well as possible local regulations.

Commissioning a Zantingh burner ought to be performed with the utmost precision and by Zantingh authorized personnel. Any commissioning work or change of settings of the burner system by somebody other than by the people mentioned above, can lead to a dangerous situation and have consequences on product liability and warranty.

Changes to the burner system may only be implemented conform instructions after receiving confirmation in writing from Zantingh.



### **REMARK:**

***Take care of your burner system as if it is the heart of your company. Restrict authorization to trained personnel only.*** Please contact your Zantingh representative or local service department in case of doubt.

## **2. DANGERS, WARNINGS AND NOTES OF CAUTION**

**NOTE:** The information included in this section is dedicated to both user and personnel charged with installation and/or maintenance

Always make sure that a copy of this manual is available in the boiler room.



### **In case of fire or any other emergency:**

When accessible close the gas valve (A1) of the gas train and switch off the main switch on the burner panel.

When there's a fire in the boiler room you need to switch off the electric power using the "fire switch" mounted on the wall outside the boiler room.

### Before you start

- The equipment must be installed by qualified personnel following the manufacturer's instructions, in compliance with the regulations in force.
- Qualified personnel means those having technical knowledge in the field of civil or industrial heating systems, electrical systems and are preferably employed by service centres authorized by the manufacturer.
- The equipment should be installed in a suitable boiler room, with ventilation openings that are sufficient to ensure a good combustion and are in compliance with the regulations in force.
- Before installing the equipment, make sure that the equipment rating (see equipment's name plate) is the same as delivery mains (electricity, gas or other fuel).
- Improper installation may cause injury to people and animals or damage to property, for which the manufacturer cannot be held liable.
- Remove all packaging material and inspect the equipment for integrity. In case of any doubt, do not use the equipment, but contact the supplier instead. The packaging materials (wooden crate, nails, fastening devices, plastic bags, foamed polystyrene, etc.), should not be left within the reach of children, as they may prove harmful.
- The equipment should be used exclusively for which it was designed. Any other use shall be considered as improper and therefore dangerous.
- Only equipment designed according to the regulations in force should be used.
- Failure to comply with the above instructions is likely to impair the equipment's safety.

### Special instructions with regard to electric power

- The equipment must be installed and efficiently grounded as required by current safety regulations.
- It is vital that all safety requirements are met. In case of any doubt, ask for an accurate inspection of electricians by qualified personnel. The manufacturer cannot be held liable for damages that may be caused by failure to correctly ground the equipment.
- Do not use gas pipes to ground electrical equipment.

- Qualified personnel must inspect the system to make sure that it is adequate to take the maximum power used by the equipment as shown on the equipment's name plate. In particular, make sure that the cable cross section of power cables are adequate for the power used by the equipment.
- No adaptors, multiple outlet sockets and/or extension cables are allowed to connect the equipment to the electric mains.
- The use of any power-operated components implies observance of a few basic rules, for example:
  - do not touch the equipment with wet or damp parts of the body and do not work on the equipment on bare feet;
  - do not pull electric cables;
  - do not leave the equipment exposed to weather conditions (rain, sun, etc.) unless expressly required to do so;
  - do not allow children or unexperienced persons to use or work on the equipment;
- The electric cables shall not be replaced by the user. In case of damage to a cable, switch off the unit and contact qualified personnel to replace it.
- When the equipment is to remain idle or not in use for some time, the electric switch supplying all the power-driven components in the system (i.e. pumps, burner, etc.) should be switched off.

#### Special warnings regarding fuel supply

- Before installation, it is recommended that all fuel supply lines be carefully cleaned inside, to remove foreign matter that might impair the burner operation.
- Before the burner is commissioned, have qualified personnel inspect the following:
  - all connections of the fuel supply system are tight and properly sealed;
  - the fuel supply flow rate matches the firing rate required for the burner;
  - the burner combustion system is designed for the available fuel type;
  - the fuel supply pressure matches the one on the name plate;
  - the dimensions of the fuel supply system are adequate to the burner firing rate, and the system is equipped with all the safety and control devices required by the regulations in force;
  - the boiler room ventilation openings are sufficient to ensure a good combustion and are in compliance with the regulations in force.
- Do not obstruct the ventilation openings of the room where gas fired equipment is installed. This might result in dangerous conditions such as the development of toxic or explosive gas composition.
- When the burner is to remain idle or not in use for some time, or in case of prolonged absence of the user, the fuel supply valves should be closed.



#### **Precautions if you smell gas:**

1. Immediately open doors and windows to create an air flow to purge the room
2. Close the gas valves
3. Do not operate electric switches, the telephone, or any other item likely to generate sparks
4. Contact qualified personnel

### Instructions regarding operation and maintenance

- The equipment shall be operated and serviced by qualified personnel only and in compliance with the regulations in force.
- Make sure that the burner system has been firmly secured to the boiler.
- Make sure that inlet or exhaust grilles are unobstructed.
- Before commissioning the burner system and thereafter at least once a year, have qualified personnel perform the following operations:
  - set the burner fuel flow rate depending on the capacity of the boiler;
  - set the combustion air flow rate to obtain the best possible efficiency;
  - check the system operation for proper combustion, to avoid any excess harmful or polluting gases regarding the regulations in force;
  - make sure that control and safety devices are working properly and mechanical locking devices of controls have been duly tightened;
  - make sure flues are in good condition and not leaking;
- To ensure equipment efficiency and proper operation, it is essential that maintenance operations are performed by qualified personnel at regular intervals, following the manufacturer's instructions.
- Before any cleaning or servicing operation, disconnect the system from the power mains by turning the master switch OFF, and cut off the fuel supply by closing the hand gas valve A1.
- Observe caution with hot burner components. They become hot during operation and will remain hot for some time after the burner has stopped.
- In case of a burner shut-down, reset the control box by means of the RESET pushbutton. If a second shut-down takes place, call the service department, without again trying to RESET.
- In case of breakdown and/or defective operation, shut off the system from fuel and electrics. Make no attempt to repair the equipment or take any other action. Contact qualified personnel instead.
- Equipment shall be repaired exclusively by a servicing centre, duly authorized by the manufacturer, with original spare parts and accessories.
- When a decision is made to discontinue the use of the equipment, those parts likely to constitute sources of danger shall be made harmless.
- In case the equipment is to be sold or transferred to another user, or in case the original user should move and leave the unit behind, make sure that these instructions accompany the equipment at all times so that they can be consulted by the new owner and/or the installer.



#### **LIABILITY:**

The manufacturer shall not be held liable, by agreement or otherwise, for damages resulting from improper installation, use and failure to comply with the instructions supplied by the manufacturer. The occurrence of any of the following circumstances may cause explosions, polluting gases (example: carbon monoxide CO), burns, serious harm to people, animals and things:

- Failure to comply with one of the instructions in this chapter.
- Incorrect handling, installation, adjustment or maintenance.
- Incorrect use of the equipment or incorrect use of its parts or optional supply.

### 3. TECHNICAL SPECIFICATIONS

To understand this manual better you need to know which type of burner has been installed (TR or RKB) and which type of system it controls. This information is provided on the name plate on the right-hand side of the burner.



**ZANTINGH**

Zantingh B.V.  
Aarbergerweg 9  
1435 CA Rijsenhout  
P.B. 255, 1430 AG Aalsmeer  
Telefoon (+31)(0)297-219 100  
Telefax (+31)(0)297-219 199  
E-Mail info@zantingh.com

**SERIAL NR.** : 24-24-2402401  
**PROJECTNUMBER** : 23000  
**TYPE** : RKB 10.0 ND-HO M GO /T  
**NOX CATEGORY** : 3  
**BUILT /MONTH** : 2024/08  
**BURNER CAT.** : B23  
**QMIN/QMAX kW(Hi)** : 1600/12950 kW  
**FUEL** : G20/Oil  
**GASPR.MIN/MAX** : 185/250 mbar  
**GAS/OIL FAMILY** : I2H/ASDM D-240  
**VOLTAGE** : 230/1~N/400/3~/50Hz/IP40  
**E - CONSUMPTION** : 40,12kW / 74,8 A  
**IP CLASS** : IP40  
**PIN NUMBER** : 1312DO6737  
**DESTINATION** : GB



1312/24

CAUTION HIGHTENSION!  
BURNER MUST BE INSTALLED IN CONFORMITY  
WITH THE LOCAL PROVISIONS.  
FOR USE IN ADEQUATE VENTILATED AREAS  
ONLY.  
READ INSTRUCTIONS BEFORE USE.



For the following information please refer to the name plate:

- serial number
- type and model of the burner
- month, year and county of manufacture
- gas pressure
- electrical power consumption and supply.

The burner type and serial number should always be reported in communication with the supplier

#### 3.1 Key to the model name:

Key - clé - sleutel:	
TR-RKB	air casing type - type caisse d'aire - type luchtkast
1.0-18.0	indication output combustion chamber - indication puissance chambre de combustion - indicatie vermogen vuurhaard
ND	indication NOx emission - indication émission NOx - indicatie NOx emissie
DKR-HO	mixing design type - type construction de mélange - type meng-inrichting
P-M	gas/air ratio adjustment; P = pneumatic, M = electronic – réglage ratio gaz/air; P = pneumatique, M = électronique gas/lucht verhoudingsregeling; P = pneumatisch, M = elektronisch
G-GO	fuel; G = gas, GO = gas/oil - combustible; G = gaz, GO = gaz/fioul - brandstof; G = gas, GO = gas/olie
/T	reference CE file - référence dossier CE - referentie CE dossier

### 3.2 Datasheet

Burnertype	output range - gas		output range - oil		Furnace back press.*(mbar)	Gas pressure range ** (mbar)	Electrical consumption		Sound level dB(A) ***
	Min kW	Max kW	Min kW	Max kW			Airfan kW	Oilpump kW	
TR 1.0 ND...M.G/O	350	1.264	337	1.011	10,0	85 - 300	3,0	0,55	73,0
TR 1.5 ND...M.G/O	350	1.896	506	1.517	10,0	85 - 300	4,0	0,55	73,0
TR 2.0 ND...M.G/O	350	2.528	674	2.022	10,0	85 - 300	5,5	0,75	73,0
RKB 2.5 ND...M.G/O	630	3.152	841	2.522	10,0	185 - 300	5,5	0,75	75,3
RKB 3.0 ND...M.G/O	759	3.793	1.011	3.034	11,5	185 - 300	7,5	0,75	76,8
RKB 3.5 ND...M.G/O	885	4.424	1.180	3.539	11,5	185 - 300	11,0	0,75	75,0
RKB 4.0 ND...M.G/O	1.011	5.054	1.348	4.043	11,5	185 - 300	11,0	0,75	75,0
RKB 5.0 ND...M.G/O	1.053	6.315	1.684	5.052	11,5	185 - 300	11,0	1,5	78,7
RKB 6.0 ND...M.G/O	1.264	7.582	2.022	6.066	11,5	185 - 300	15,0	1,5	78,0
RKB 7.0 ND...M.G/O	1.475	8.848	2.359	7.078	11,5	185 - 300	18,5	2,2	78,7
RKB 8.0 ND...M.G/O	1.680	10.103	2.694	8.082	12,5	185 - 300	22,0	2,2	83,7
RKB 9.0 ND...M.G/O	1.900	11.377	3.034	9.102	13,5	185 - 300	30,0	2,2	81,8
RKB 10.0 ND...M.G/O	1.900	12.641	3.371	10.113	15,5	185 - 300	37,0	2,2	84,6
RKB 12.0 ND...M.G/O	2.200	15.169	4.045	12.135	15,5	185 - 300	45,0	3,0	85,3
RKB 14.0 ND...M.G/O	2.500	17.698	4.719	14.158	17,5	185 - 300	75,0	3,0	85,3
RKB 16.0 ND...M.G/O	2.800	20.226	5.394	16.181	17,5	185 - 300	95,0	4,0	85,3
RKB 18.0 ND...M.G/O	3.000	22.754	6.068	18.203	19,5	185 - 300	110,0	5,5	85,3

\* Negative back pressure in the boiler is not allowed

\*\* All values for the gas circuit are valid for methane gas G20 according to EN 437 (at atm pressure 1.013 mbar and temperature 15 ° C)

\*\*\* Noise measured at a distance of 1 m from the burner body (EN ISO 3744)

## **4. PRODUCT SPECIFICATION**

The Zantingh burner systems are made in two variants:

Variant 1 is the **TR**-burner system. In this model burner and fan are directly linked and is therefore called a **monoblock** system. This system is made for a burner output capacity of 1.163 kW up to 2.326 kW.

Variant 2 is the **RKB**-burner system. In this model burner and fan are separate and connected by means of flexible sleeves. It is therefore called a **duoblock** system. This system is made for a burner output capacity of 2.900 kW up to 13.956 kW. In the lower capacity range (2.900 kW – 4.650 kW) the RKB-burner system controlled by **LMV** has an integrated switch board in the burner housing and is called an **RKB compact** burner.

The burner control in both variants is fully electronic and can be **Autoflame** or **Siemens LMV**.

### **4.1 Burner component**

The burner component is in a welded steel-plated housing. Under the burner housing there's an air valve section, it controls the air supply to the burner. A servomotor drives the valves.

The primary and secondary burner combustion devices are situated in the cylindrical part of the burner. The flame monitoring device is mounted on the side of the cylindrical part.

The gas supply connection to a servomotor-driven gas quantity control valve is located under the cylindrical part of the burners.

### **4.2 Air fan component**

The air fan is positioned under the burner. The fan wheel is driven by an electromotor. The air fan of a **TR burner** is directly connected to the air-valve section. The air fan of an **RKB burner** is separate and stands on the floor. The connection is made using a flexible sleeve. Vibration isolators are used when mounting the air fan on the floor.

The standard air fan includes an inlet grid to prevent coming into contact with moving parts. A plate silencer is provided on the air fan inlet for noise reduction purposes. Cylindrical noise silencers are available as an option.

### **Frequency control**

A circuit in the control panel controls the air fan electromotor. A frequency control unit, not included on the control panel, controls the air fan rotational speed based on the burner load. The speed is controlled directly from the burner control unit by sending a 0-10 V/4-20 mA signal to the frequency control unit.

The frequency control unit is programmed for its specific purpose by the burner manufacturer.

### 4.3 Gas train

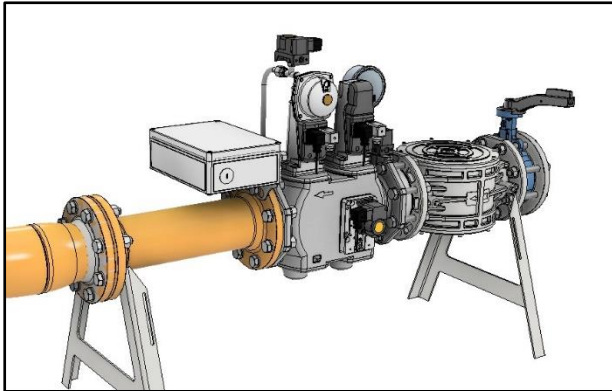

Figure 1 gas train

The gas train controls the gas supply from the distribution network. Several monitor and control units are mounted on the gas train to control the burner gas supply.

#### **NOTE:**

**The maximum supply pressure for the system is indicated on the burner name plate.**

The gas train is generally placed at left- or right-hand side of the boiler. It is connected to the burner by means of a separately delivered and custom-made **gas pipe**.

The gas train includes a pilot gas supply to the burner's ignition system.

### 4.4 Oil supply

When not specifically stated otherwise, the burner is made for oil as emergency fuel only with high/low controls. The burner is capable of oil firing during 2x24 hours maximum.

If the burner is equipped for oil firing, it comes with a two or three nozzle oil combustion system, depending on the capacity of the burner. It is mounted in the burner component.

### 4.5 Control panel

The control panel of a **TR-monoblock** system is separately delivered. The electronic module for burner control (only Siemens LMV) is integrated in the burner casing though and not in the burner control panel.

The control panel of the **RKB compact** burner (RKB 2.5-4.0) is fully integrated in the burner housing if you have a Siemens LMV controlled burner.

The control panel of the larger type **RKB burners** (from RKB 5.0) is separately delivered. The electronic module for burner control (Siemens LMV) is integrated in the burner control panel and not in the burner housing as is the case with a TR burner system.

If you have an Autoflame controlled burner, the Autoflame module is integrated in a separate control panel for all burner types.

The control panel includes all electrically controlled operation, monitoring and control units of the burner, air fan, gas train, boiler and other secondary connected devices. The electric circuits of all devices and units are connected to the control panel in such a way that the total system can operate safely.

These circuits can be classified into the following main groups:

- Boiler/safety circuit.
- Thermostat (start) circuit.
- Burner control.
- Load control.
- External control (Fiduface).
- Failure indicator lights.
- Motor groups/fuses.
- Control switches and reset buttons.
- Optional CO<sub>2</sub>-circuit and CO-detector circuit.
- Condenser alarm.



**NOTE:**

**Always refer to the electrical drawings that come with the burner. Because each unique burner panel has its own unique electrical drawings.**

## 5. ASSEMBLY



### IMPORTANT:

Zantingh burner installation may only be installed by notified installer companies that know their way in and work according to local regulations. This concerns both assembly and electrical connection of the installation.

When positioning the installation make sure that you leave enough space on both sides of the burner for service purposes.

### 5.1 Mounting the burner on the boiler

The burner is equipped with a mounting flange with slotted holes, that should fit the threaded holes in the boiler front plate. Check their correct position before you start lifting the burner.

If there are no holes in the boiler front, apply the pattern of the burner drilling holes on the boiler front plate as instructed on the by Zantingh provided drawing and follow also the instructions of the boiler supplier.



### IMPORTANT:

**Do not use the pre-installed silicon gasket on the burner mounting plate for marking purposes, as it is easily damaged. Also, if the gasket is already damaged, replace it.**



Before starting make sure that there are no materials, people or animals in the boiler's furnace.

Apply a thin layer of (the by Zantingh provided) silicon paste to the pre-installed gasket on the burner mounting plate. The paste should be in any case heat-resistant to a temperature of up to 190 °C.

Figure 2 Burner mounting plate with slotted holes

Use reliable lifting equipment, which has at least the complete burner section's weight capacity. **The burner should always be held horizontally.** The on the burner installed lifting hook is not always located in line with the burner centre of gravity. Use additional slings or supports while levelling if necessary.

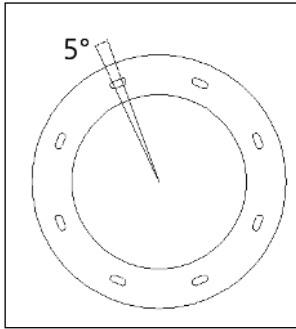

Position the burner in front of the boiler. To simplify assembly and to allow the burner to be fitted upright to the boiler, slotted holes are used. The maximum rotation of the burner is 5 degrees, see figure 3.

Figure 3 Maximum burner rotation mounted to the boiler

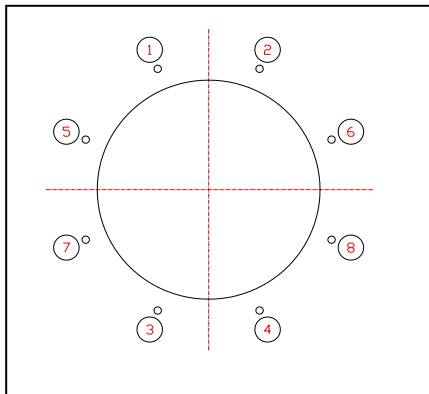

- Take into account the following:
- Always use washers underneath fastening bolts and nuts.
  - The quality of the (stud) bolts should be at least 8.8.
  - The total width of the burner flange and gasket adds up to approximately 38 mm.
  - Use gas fitter tape around the fastening bolts to prevent corrosion.
  - Tighten the nuts or bolts in the right order, see figure 4.

Figure 4 Order of tightening bolts

### **5.1.1 Brickwork**

Always use brickwork around the burner head to prevent overheating of the boiler front. The brickwork is applied on the inside of the boiler's furnace around the burner head. The burner head should always be at least 200mm beyond the brickwork, see figure 5. In case of a water-cooled boiler front no extra isolation is needed, but the gap between the burner head and boiler must still be closed using brickwork.

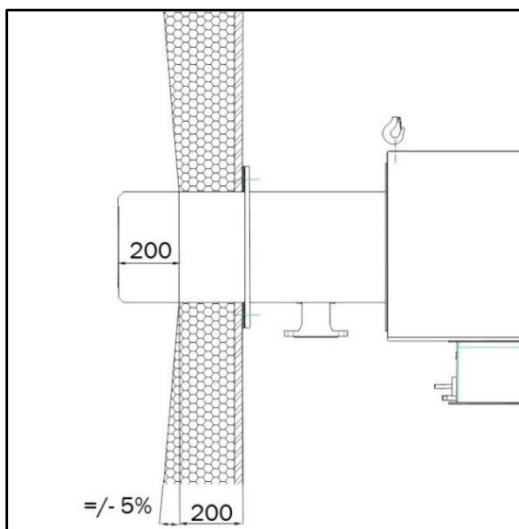

Figure 5 Brickwork

## 5.2 Air fan connection



### **IMPORTANT:**

Never put the air fan into operation. The outlet side must be connected to the burner and the inlet to a silencer and/or the supplied safety grid. The motor may overload if the counter pressure is not sufficient.

If the suction side is connected to an air duct, the fitter should ensure that it is constructed according to the CE Machinery Directive and to additional local regulations. The fitter has to produce a certificate stating this.

### **5.2.1 Mounting the air fan of a TR burner installation**

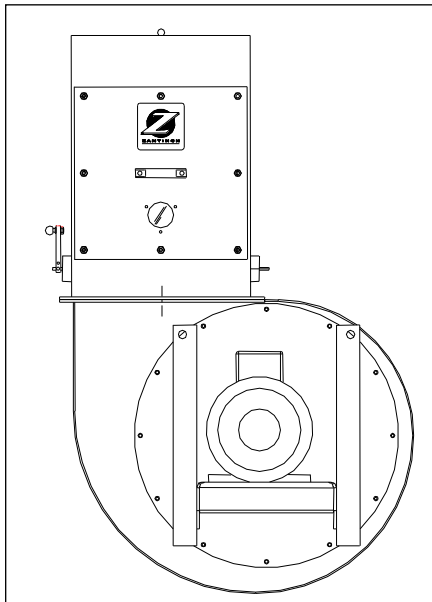

Figure 6 TR burner with fan

The air fan of the TR burner model is suspended below the burner and has to be fixed directly to it as shown in figure 6.

**The inlet side of the air fan with safety grid should always point towards the boiler.**

**Always check the general layout drawings that come with the installation for the right positioning of the fan underneath the burner with respect to the boiler position.**

To seal the burner-fan connection, use the by Zantingh provided self-sticking sealing tape. Make sure that the tape is applied on the inside of the hole pattern and also doesn't cover any holes. The ends of the sealing tape should come together in the corners to prevent leakage.

Make sure there are no loose parts in the fan casing before fixing the air fan to the burner. Use the by Zantingh provided bolts and nuts to fix the air fan to the burner.



Figure 7 sealing tape application

### 5.2.2 Mounting the air fan in an RKB burner installation.

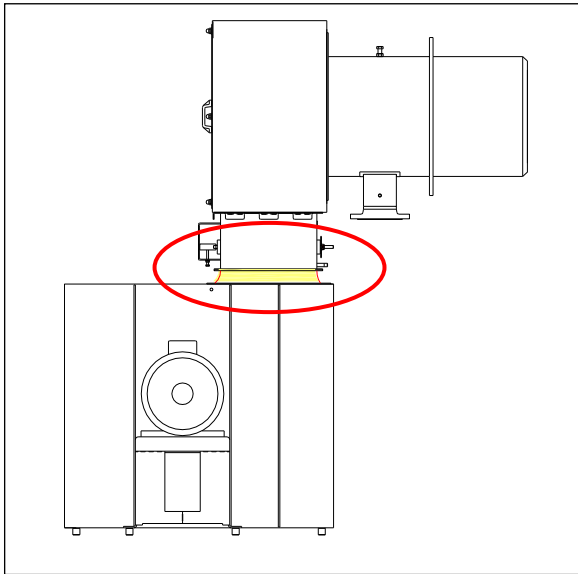

The air fan of the RKB burner model stands on the ground and has to be connected to the burner using a flexible sleeve, see figure 8 (yellow).

Make sure that the flexible sleeve itself is 10-20 mm longer than the distance between the burner and the fan. This way this flexible section of the installation can absorb movement without being damaged.

The fan is fixed to the ground with vibration dampers to prevent movement and shifting and a change of position with regard to the burner.

Figure 8 RKB burner with fan

#### **NOTE:**

**Always check the provided general layout drawing for the correct positioning of the air fan with respect to the boiler / burner.**

#### **Steps for connecting a fan of an RKB burner:**

1. Apply the by Zantingh provided self-sticking sealing tape to the flange on the fan. Make sure that the tape is on the inside of the hole pattern and doesn't cover any holes, see picture.



2. The ends of each piece of sealing tape should come together in the corners.

3. Fix the flexible sleeve on the air fan flange with sealing tape, using the provided counter flange and bolts and nuts.

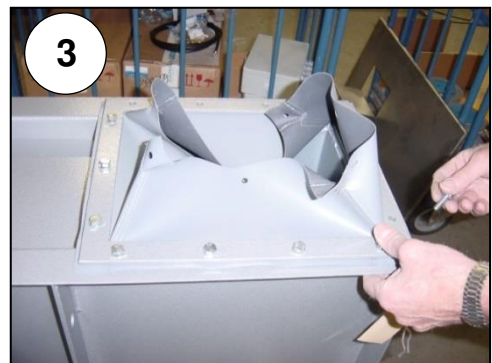
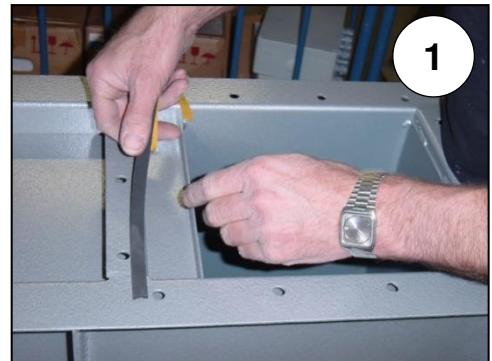

4. Position the fan's air outlet exactly below the burner's air inlet / air valve section. Now mark the holes of the air fan on the ground.

5. Remove the air fan and drill the holes with size 8 or 10 mm, depending on the size of the vibration dampers.

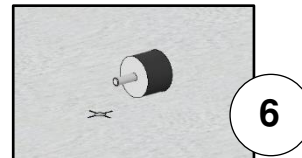
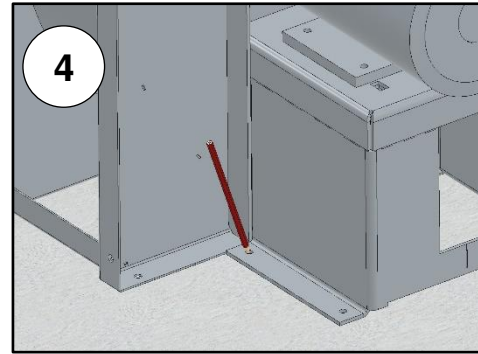
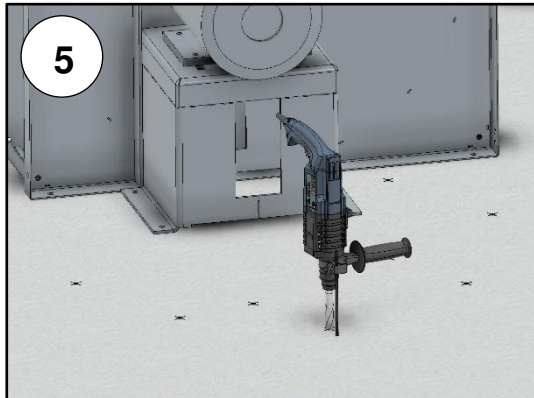

6. Place the vibration dampers with the threaded end in the holes in the floor and place the air fan on top of it.

7. Fix the air fan to the dampers with the provided bolts.

8. Now repeat step 1 to 3 on the burner flange.

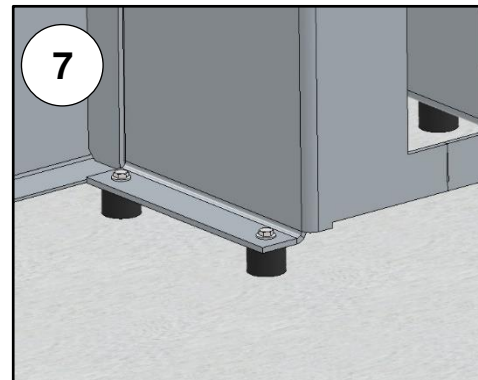

### **5.2.3 Air fan with an additional air duct**

When the boiler furnace is not high enough for the burner in combination with the air fan, an air duct has to be used between the air fan and burner. In this case the air fan is positioned in front of or next to the burner. The flexible sleeve (yellow) is used to make the connection to the air fan, see figure 9. At the burner side the air duct is fixed to the burner's air valve section same as a TR burner, using the self-sticking sealing tape as shown in figure 8.

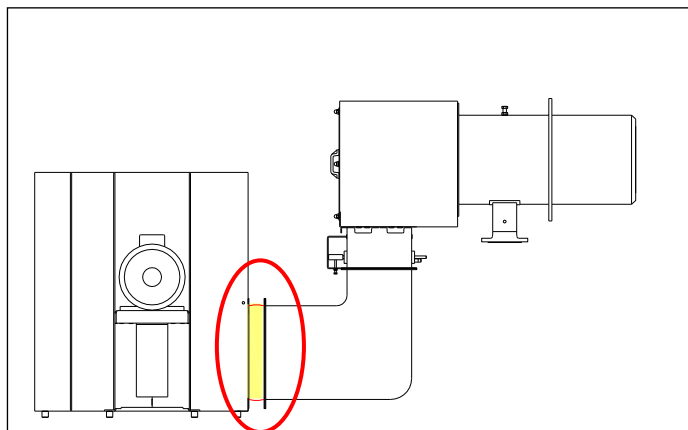

Figure 9 Air duct

### Steps to correctly mount a burner installation with an air duct:

1. Fix the inlet duct directly to the burner by following the steps in paragraph 5.2.1. See for correct positioning the provided general layout drawings.
2. Now fix the flexible sleeve to the air fan by following steps 1-3 in paragraph 5.2.2.
3. Position the air fan in a way that the centre of the fan matches the centre of the air duct's inlet side, keeping approximately distance between the air fan and air duct for the flexible sleeve.
4. Then fix the air fan to the ground by following steps 4 -7 in paragraph 5.2.2.
5. Now repeat steps 1-3 in paragraph 5.2.2 to connect the air duct to the air fan with the flexible sleeve.

### 5.3 Mounting the gas train



#### **IMPORTANT:**

Connect the gas train to the gas pipes, the burner and the outside air (relief valve) according to the gas train diagram and **local regulations**.

In most cases the gas train will be placed (left/right) next to the boiler. Before installing the gas train make sure it was designed for the left- or right-hand position of the boiler, see provided layout drawings. The electrical connections should in any case be visible when facing the gas train. An arrow on the gas train indicates the direction of the gas flow. Always make sure that the components of the gas train are accessible for maintenance.

#### **5.3.1 Main gas supply connection**

The gas train has to be connected to the burner by means of a piece of gas pipe. This gas pipe is either provided with the burner by Zantingh or it has to be made on site.

NOTE: Please refer to the provided general layout drawings to find the correct positioning of the gas pipe.

#### **When making this connection please take into account the following:**

- Always respect local regulations.
- Measure and mount the gas pipe avoiding stress between the burner and the gas train.
- The diameter of the gas pipe should be equal to either the burner connection or the gas train connection, whichever is the largest of the two.
- The maximum allowed length of this section is 4 meters.

Now connect the other side of the gas train to the main gas line respecting local regulations. **Avoid stress between the gas train and main gas line at any time.**

**Note!** The diameter of the gas train does not determine the diameter of the main gas line!

The inlet pressure on the gas train (at hand valve A1) should under no circumstances exceed the maximum value mentioned in the technical specifications (see gas train diagram) and on the burner name plate.

**When testing the gas lines, first close hand valve A1 and decompress the gas train to prevent damage to its components due to high pressure.**



### **IMPORTANT**

If you have a high gas pressure regulator installed in the gas train (see gas train diagram), it is usually set up for the installation's preferences by the burner manufacturer. Contact the Zanting service department if you have any questions.

#### **5.3.2 Pilot gas connection**

The pilot gas line is installed on the gas train and has to be connected to the burner only after the positioning and connection of the gas train to the burner and main gas line.

The pilot gas line is the 15 mm pipe line on the gas train and it has to be connected to the burner, right under the burner housing, see figure 10. The pipe line and connection materials to connect the pilot gas are included in the delivery.

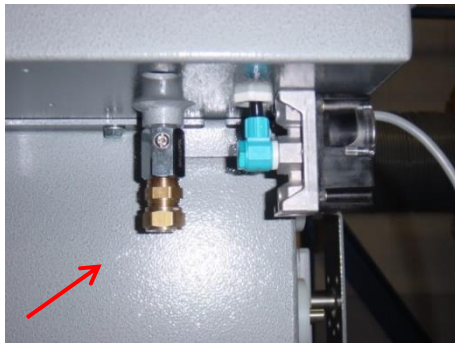

Figure 10 The pilot gas connection

#### **5.3.3 Relief lines**

A bleed/relief line has to be installed to be able to remove the gas from the gas train when performing maintenance. Make a pipe through the roof to the outside air and connect it to position "ZG" on the gas train, refer to gas train diagram. The opening of the bleed line in the outside air has to be protected against dirt and rain.

#### **5.3.4 Measuring lines (only Autoflame)**

If you have an **Autoflame** controlled burner, the gas flow to the burner is pneumatically controlled by measuring the furnace and air pressure. The synthetic measuring lines for air and furnace pressure have to be connected to the SKP75 gas control valve. Refer to the gas train diagram positions "PF" (furnace pressure) and "PL" (air pressure).



Figure 11 Connecting the air pressure sensor

To measure the air pressure, connect the measuring point on the air valves section on the burner to position “PL” on the gas valve, using the supplied synthetic tube, see figure 11.

To measure the furnace pressure a cooling coil has to be installed on the boiler front. Drill a hole through the brickwork of the boiler. Install a ¼ " socket by welding it to the boiler front. Mount the cooling coil on the socket and connect the supplied measuring line to the gas valve on position “PF”, see figure 12.

Always prevent twists and syphon effects while installing the measuring lines.

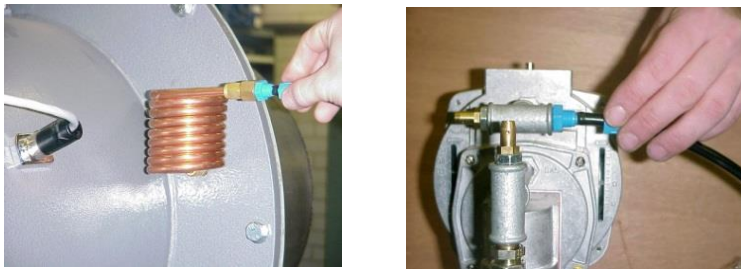

Figure 12 Installing the cooling coil

#### 5.4 Oil supply connection

When not specifically stated otherwise, the burner is made for oil as emergency fuel only with high/low controls. The burner is capable of oil firing during 2x24 hours maximum.

When the burner is designed for oil firing during a longer period of time (oil modulating), please contact your Zantingh supplier if you need additional support connecting the oil lines



#### **IMPORTANT:**

Refer to the oil diagrams provided with the burner when connecting the oil lines. The oil connections should always comply with local environmental requirements and applicable standards.

In each oil system an oil filter must be installed of which the dimensions match the capacity (oil flow/consumption) of the burner. For the oil consumption per type refer to the table in figure 12 on the next page. Oil consumption is based on a caloric value of **42.60 MJ/kg**.

General characteristics for oil:

- Min-max pressure: -0,2-0,5 mbar
- Density: 830 kg/m<sup>3</sup>
- Viscosity: 1,3°E @ 20°C

Burner type	Capacity	Oil consumption		Motor kW	
		80%	kg/h		l/h
TR	1	1.011	85	103	0,37
TR	1,5	1.517	128	155	0,37
TR	2	2.023	171	206	0,37
RKB	2,5	2.528	214	258	0,75
RKB	3	3.034	256	310	0,75
RKB	3,5	3.540	299	361	0,75
RKB	4	4.045	342	413	0,75
RKB	5	5.057	427	516	0,75
RKB	6	6.068	513	619	1,5
RKB	7	7.079	598	722	1,5
RKB	8	8.090	684	826	2,2
RKB	9	9.102	769	929	2,2
RKB	10	10.113	855	1.032	2,2
RKB	12	12.136	1.026	1.238	3,0

Caloric value 11,83 kW/kg 9,8 kW/L

Figure 13 Oil consumption per burner type @ 80% capacity of gas firing

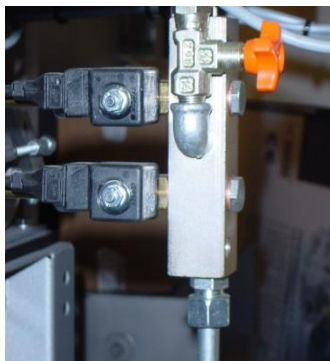

A 12 mm connection for the oil supply line is located underneath the burner housing. To this connection the return line of the separately supplied oil pump or the oil pump on the supplied oil buffer system has to be connected.

All oil connections are compression fittings.

Figure 14 Oil line connection to the burner

#### **5.4.1 Oil pump installation**

An oil pump is delivered separately and has to be installed close to the burner. Refer to figure 14 for connecting the delivered oil pump.

The oil pumps are not of the self-suction type. This means that the oil must be transported to the oil pump. The over pressure of an (above the ground) oil tank can be used for this purpose, when connecting the bottom of the oil tank to the burner oil pump. Or you can choose for a separate oil supply pump, that transports the oil with a slight overpressure of 0.5 Bar to the burner oil pump. This pump has to be installed on the oil tank from which it transports the oil to the burner.



Type: 0,37-5,5kW  
S: Supply  
R: Return  
P: overPressure

Figure 15 Oil pump for TR/RKB burner

See figure 13 on the previous page for the right information regarding the oil pump motor power.

#### **5.4.2 Oil buffer system**



Figure 16 The oil buffer tank

It is highly recommended to install an oil buffer tank if you make use of emergency oil. An oil tank minimizes the risk of air in the fuel when it comes into the burner. The combustion will be steadier and the life span of the oil pump will be prolonged. It is also more likely to have a permanent static pressure on the oil pump.

If ordered together with an oil buffer system the oil pump is mounted on the buffer system.

## 6. ELECTRICAL CONNECTION



### **IMPORTANT:**

Never perform any maintenance or any other activity on the burner (system) without adequate knowledge and understanding of the system. When performing any activity on the system, always switch off the main switch and make sure that it cannot be switched on!

See **Annex 2** for a table with numbers and cables for each burner model.

The explanations below are common situations. Always check the wiring diagrams (terminal block diagram with instructions) provided with the burner when connecting the burner, air fan, gas train, switch panel and appendages electrically. These wiring diagrams represent the actual situation for your installation.

Most connections are plug-in terminals. **Please see Annex 3 for the instructions.**



### **NOTE AUTOFLAME BURNERS:**

**for connecting an Autoflame controlled burner a separate additional manual is issued. Please contact the manufacturer for this manual if you do not have it!**

#### 6.1 Connecting a Siemens LMV26 controlled TR burner

A **TR burner** has a separate control panel that has to be connected to the burner. The **Siemens LMV26** control unit is located inside the burner housing.

The burner is prewired, which means that most cables are already installed on the burner and its components and that it has cables installed on the gas train components to connect to the burner.

##### 6.1.1 Connecting the burner to the switch panel

Use the supplied multi-wire cable 24 x 0,75 mm<sup>2</sup> to connect the **burner terminal box to the switch panel**. The cable is generally prewired to the burner. Check the wiring diagram for correct terminal numbers.

##### 6.1.2 Connecting the gas train

The cables to connect the **gas train components** are labelled and prewired to the **burner**. Connect the cables with the plugs to the corresponding numbers on the gas train components.

##### 6.1.3 Connecting the air fan motor and frequency drive

Before electrically connecting and testing the fan and/or frequency drive, check if the outlet of the fan (pressure side) is connected air tight to the burner and the inlet of the air fan (suction side) has a safety grid.

### Frequency drive power supply to switch panel

For its power supply a 10-meter cable is prewired to the frequency drive, which has to be connected **to the switch panel**. Check the wiring diagram for the correct terminal numbers.

### Frequency drive controls to switch panel



This cable is prewired to both the VSD and the burner and is separated by a plug, see figure 17. Simply plug it in to each other.

Figure 17 Plug connection

## 6.2 Connecting a Siemens LMV26 controlled RKB compact burner

An **RKB compact burner has no separate control panel**. The switch board with **Siemens LMV26** control unit is integrated in the burner housing. The gas train components have to be connected to the burner.

### 6.2.1 Connecting the gas train components

The cables to connect the **gas train components** are labelled and prewired to the **burner**. Connect the cables with the plugs to the corresponding numbers on the gas train components.

### 6.2.2 Connecting the air fan motor and frequency drive

Before electrically connecting and testing the fan and/or frequency drive, check if the outlet of the fan (pressure side) is connected air tight to the burner and the inlet of the air fan (suction side) is connected to the supplied safety grid and/or a damper.

### Frequency drive power supply to switch panel

For its power supply a 3-meter cable is prewired to the frequency drive, which has to be connected **to the burner**. Check the wiring diagram for the correct terminal numbers.

### Frequency drive controls to burner

This cable is prewired to both the VSD and the burner and is separated by a plug. Simply plug it in to each other, see figure 17 on previous page.

## 6.3 Connecting a Siemens LMV5 controlled RKB burner

An **RKB burner** equipped with a **Siemens LMV5** control system has a separate control panel in which the LMV5 module is integrated. It has to be connected to the burner terminal box, to the gas train terminal box and various devices.

See **Annex 1** for an example layout drawing and location of parts.

If a cable set is supplied with the burner, these cables have to be used. If not, **please be sure to use the advised cables as mentioned in the following paragraphs and the list of cables in Annex 2.**

### **6.3.1 General instructions for EMC cables**

When using screened or EMC cable with or without glands, please carefully follow the instructions below.

- Do not remove the insulation of a screened cable over more than 30mm (strip as little as possible).
- Fasten the screen under the special screen cable clamps and then with the special screen terminal to be sure of good surround contact. Refer to the electrical diagram for the correct terminal numbers. do not connect to the common ground terminal.
- When fastening the cable with an EMC gland, make sure that the screen makes surround contact in the EMC gland, see annex for EMC gland instructions. Do not twist the screen together (pigtail) and do not connect to the common ground terminal. See EMC gland instructions in Annex 4.



### **INSTRUCTION**

Check the EMC gland instructions in Annex 4.

### **6.3.2 Connecting the burner terminal box**

Use a multi-wire cable 12 x 0,75 mm<sup>2</sup> to connect the **burner to the switch panel.** Check wiring diagram for correct terminal numbers in both burner terminal box and switch panel.

### **6.3.3 Connecting the gas train terminal box**

All gas train components are wired to the gas train terminal box. Use a multi-wire cable 25 x 0,75 mm<sup>2</sup> to connect the **gas train terminal box to the switch panel.** Check wiring diagram for the correct terminal numbers in both gas train terminal box and switch panel.

### **6.3.4 Connecting the servo motors**



The servo motors for the air and gas valves are interconnected. Only the **gas valve servo motor** has to be connected to **the switch panel.**

Use the separately delivered **Siemens CAN-bus cable** to make the connection. This cable is prewired to the switch panel.

See figure 20 for correct connection on the servo motor connection box.

Figure 20 Servo motor connections

### 6.3.5 Connecting the air fan motor and frequency drive

Before electrically connecting and testing the fan, check if the outlet of the fan (pressure side) is connected air tight to the burner and the inlet of the air fan (suction side) is connected to the supplied safety grid and/or a damper.

#### **Frequency drive to air fan motor**

The frequency drive of an **LMV 5 controlled RKB burner** is delivered separately and generally placed next to the burner switch panel.

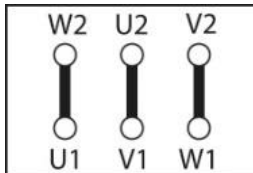

First check the motor windings of the fan motor for 'delta' setting, see figure 21. For information, also see the drawing on the cover of the fan motor connection box.

Figure 21 Delta setting fan motor

The frequency drive has to be connected to the air fan motor with an **EMC cable**, 3 phase + safety grounding (green-yellow) **with EMC gland** on the air fan motor side.

Refer to the table in **Annex 5 for cable and gland sizes**.

Refer to **paragraph 6.3.1** for instructions for screened cables.

Refer to **Annex 4 for EMC gland instructions**.



#### **INSTRUCTION**

Check the Annex for EMC gland instructions and cable and gland sizes.



Figure 22 Frequency drive connections

For connection details on the **VSD side**, refer to figure 22.

Then connect the wires to the terminals **U1, V1 and W1** in the air fan motor connection box.

#### **Frequency drive power supply to switch panel**

Refer to figure 22 frequency drive connections. For the power supply from the **switch panel to the frequency drive** use a **power cable**, 3 phase + safety grounding (green-yellow). Connect the cable to the terminals **L1, L2 and L3** in the frequency drive and **U, V and W** on the switch panel side.

#### **Frequency drive controls to switch panel**

Refer to figure 22 for frequency drive connection.

To connect the **control cable from the switch panel to the frequency drive**, use a  $8 \times 0,75\text{mm}^2$  multiwire **screened cable without glands**, 3 phase + safety grounding (green-yellow). Check the wiring diagram for the correct terminal numbers.

Refer to paragraph 6.3.1 for instructions for screened cables.  
For more wiring details, see wiring diagram.

### Connecting the speed sensor

In case of an **LMV5 controlled burner** the speed sensor is connected to a small connection box on the air fan. Use a 3 x 0,75mm<sup>2</sup> **screened** cable without glands to connect it to the switch panel. Check the wiring diagram for the correct terminal number.

Refer to **paragraph 6.3.1 for instructions** for screened cables.

### 6.3.6 Connecting the UV cell

The UV cell is prewired to the burner. Use a separate **screened** cable 3 x 0,75mm<sup>2</sup>, without EMC gland, to connect the UV-cell **from the burner terminal box to the switch panel**. Check the wiring diagram for the correct terminal number.

Refer to **paragraph 6.3.1 for instructions for screened cables**.

### 6.4 Burner load control

The burner load controller is controlled by a boiler temperature sensor PT1000.



Figure 23 PT1000 thermometer

The PT1000 temperature sensor has to be wired with a **screened** cable (CY 2x0,75mm<sup>2</sup>) without glands. Refer to **paragraph 6.3.1 for instructions for screened cables**.

Because the sensor itself has no terminal to connect the screen to, it must be insulated properly. Make sure that the screen does not make contact to the sensor.

### 6.5 Oil pump to switch panel connection



#### **INSTRUCTION**

Check the Annex for EMC gland instructions and cable and gland sizes.

Depending on type of motor (see motor type plate) the motor windings can be in star, delta or star/delta. For connection details, see drawing on the cover of the connection box of the motor, and electrical diagram of the burner switch panel.

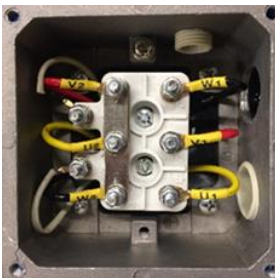

Figure 24 Oil pump connections

To connect the oil pump, use a **power cable**, 3 phase + safety grounding (green-yellow) with gland on the oil pump side.

Connect the wires of the power supply from the burner panel on terminals U1, V1 and W1 to the oil pump.

Refer to the table in **Annex 6 for cable and gland sizes**.



### **IMPORTANT:**

Refer to the oil diagrams provided with the burner when connecting the oil lines. The oil connections should always comply with local environmental requirements and applicable standards.

## 6.6 Boiler safeties

### 6.6.1 Low water device



Figure 25 Low water electrode

**Low water electrode CL:** must be wired with a separate (screened) cable  $4 \times 0,75 \text{mm}^2$ . When using a screened cable, the wire must absolutely be isolated from ground. Check the wiring diagram for correct terminal numbers.

A **low water floating device SYR 2"** (drawing in Annex 7) must be wired with a separate (screened) cable  $4 \times 0,75 \text{mm}^2$ . When using a screened cable, the wire must absolutely be isolated from ground. Check the wiring diagram for correct terminal numbers.

### 6.6.2 Maximal thermostat



Figure 26 Maximal thermostat

**Max thermostat:** has to be wired with a separate cable CC  $4 \times 0,75 \text{m}^2$ . Check the wiring diagram for correct terminal numbers.

## 6.7 Fiduface connections to the climate computer

The FIDUFACE is an interface between a (gas) burner installation and a greenhouse climate computer. The Fiduface is no separate device, but an integrated electrical circuit inside the burner switch panel.

Through agreements between burner manufacturers and suppliers of climate computers, the terminal numbers for connecting the climate computer are standardized. The advantage of this is that every burner equipped with Fiduface, is able to communicate with a computer with a Fiduface output.

When the burner is controlled with Fiduface, the actual greenhouse climate control is done by the climate computer. Safety related control however will always remain with the burner electronics, so that no unsafe situation can be created.

The climate control is “given back” to the burner when the climate computer is not functional.

Connections:

The **digital inputs** of all Zantingh burners is equal:

Terminal number	Description	Voltage
<b>600</b>	Common Zero of all outputs	24V AC/DC
<b>601</b>	Burner On/Off	24V AC/DC
<b>602</b>	-	-
<b>603</b>	Burner load higher	24V AC/DC
<b>604</b>	Burner load lower	24V AC/DC
<b>605</b>	CO2 flue gas valve open	24V AC/DC
<b>606</b>	Computer functional	24V AC/DC

There is a difference however for the **analogue outputs** between burners equipped with LMV2 (**TR and RKB compact**) and burners equipped with LMV5 (**RKB 5.0 – 12.0**):

**TR and RKB Compact** with LMV2:

Terminal number	Description	Output
<b>640</b>	Analogue output burner load (real time)	4 – 20 mA -
<b>642</b>	Analogue output burner load (real time)	4 – 20 mA +
<b>649</b>	Screen	-

**RKB 5.0 – 12.0** with LMV5:

Terminal number	Description	Output
<b>639</b>	Screen	-
<b>640</b>	Analogue output burner load ( calculated )	4 – 20 mA -
<b>645</b>	Analogue output burner load ( calculated )	4 – 20 mA +
<b>646</b>	Analogue output burner load from BMS	4 – 20 mA +
<b>647</b>	Analogue output burner load from BMS	4 – 20 mA -
<b>648</b>	Screen	-

The feedback signal is equal for all burners: **4-20 mA**.

## **7. PUTTING INTO OPERATION**

Due to its specialist characteristics and the many possible configurations, commissioning a Zantingh burner ought to be performed with the utmost precision and by Zantingh authorized personnel.

Any commissioning work or change of settings of the burner system by somebody other than by the people mentioned above, can lead to a dangerous situation and have consequences on product liability and warranty.

The guarantee becomes null and void if the instructions are not followed. Zantingh cannot be held liable for these damages

## **8. WARRANTY CONDITIONS**

Zantingh B.V. guarantees this Zantingh product for the installer under the following conditions. The installer guarantees this product to the user under the same conditions which are provided below.

1. The period of guarantee is valid as from the day of delivery on location. The guarantee has a fixed period of 12 months, based on the agreed sales price.
2. A recognized installer should install the system according to the applicable general and local standards and regulations based on the assembly and operation instructions provided by Zantingh.
3. The system may not be moved from the original location.
4. The guarantee becomes null and void if and when:
  - Defects of the system are not reported in writing to the installer and/or Zantingh B.V. immediately after having been discovered or these could reasonably be expected to have been discovered.
  - Defects are caused by errors, improper use or neglect by the installer and/or the user who has placed the order or his/her legal successor or caused by external causes.
  - During the period of guarantee a third party is requested to or implements changes to the system or when the user has done so without prior written consent by the authorized installer and/or Zantingh B.V.
  - During the period of guarantee the expert inspections and/or maintenance work are periodically not performed even though the equipment requires it.
  - Corrosion has been caused by polluted flue gas, to be determined by Zantingh B.V.
  - If after research is carried out, one or more of the above conditions were not taken into account and are the reason for any guarantee claim, the costs for the required research by Zantingh B.V. or third parties will be charged to the user.
5. The initial request based on the guarantee obligations described in this article should be submitted in writing to the installer within five working days after the error or defect has been observed or could reasonably have been observed.
6. The stipulations included in our general guarantee, sales and payment conditions, issued by the ORGALIME S 2012 “General conditions for the supply of mechanical, electrical and electronic products” are also applicable. Zantingh B.V. will not be liable for any consequential damage to the Zantingh system other than a defect covered by the guarantee as described above. Moreover, Zantingh B.V. will not be liable for any damage to income and/or loss of profit to the user of any nature whatsoever.
7. Any costs incurred by assembly or disassembly, travelling or accommodation expenses, constructional costs and such required to execute the terms of the guarantee are excluded from the terms of the guarantee.

Any dispute between Zantingh B.V. and the buyer regarding a claim based on the guarantee will be resolved by an expert and independent authority if so desired. The parties agree to abide by the binding decision of said authority.

# ANNEX

## 1. Lay out and location of parts

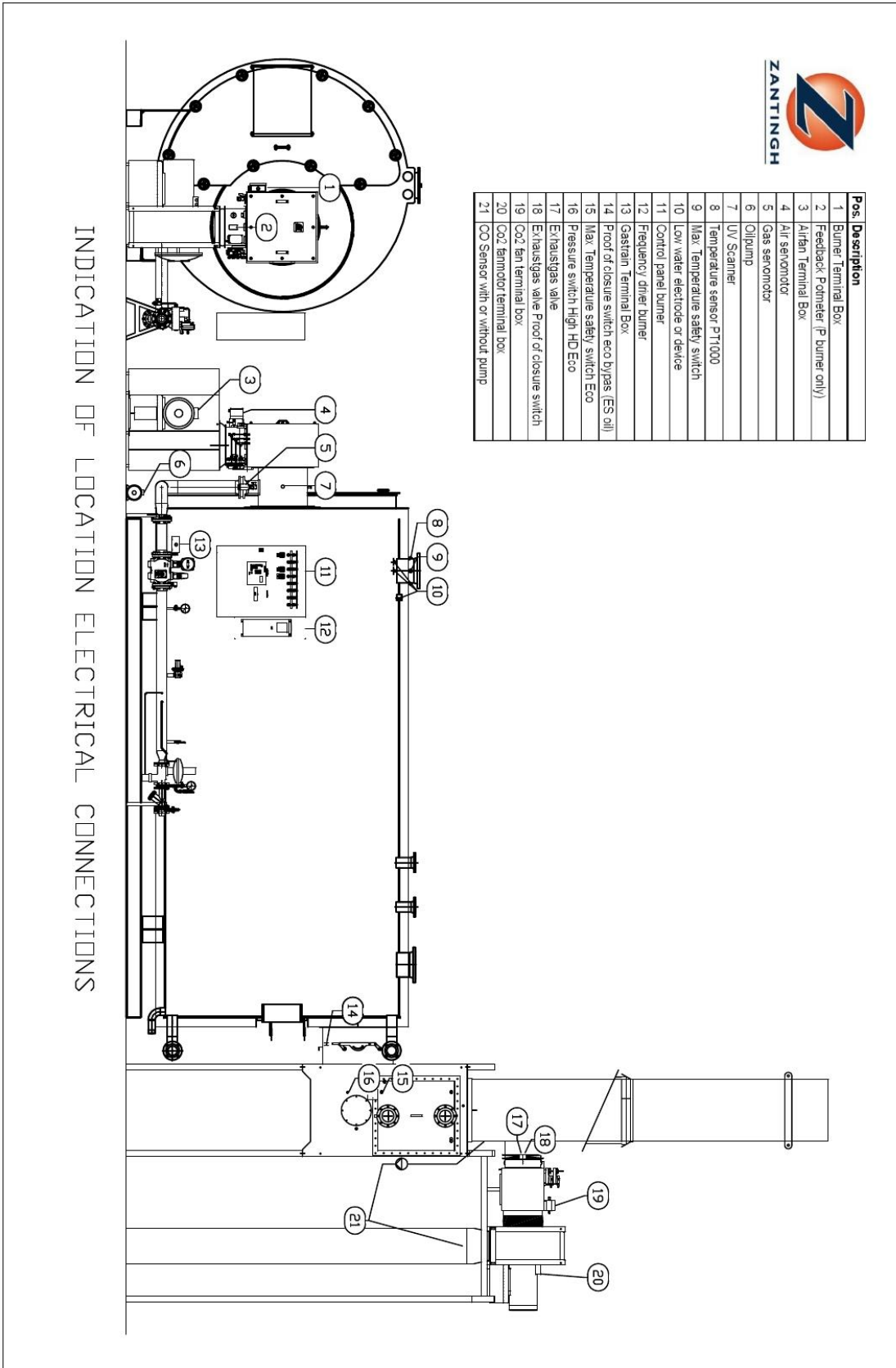

## 2. List of cables

No.	Part	Connection	Cable	Supplied
<b>TR burner with LMV 26 integrated in burner housing</b>				
1	Switch panel	From burner to switch panel	Multiwire 25x0,75mm <sup>2</sup> (CC)	YES
2	Gas train	From gas train components to burner	Plug & Play	YES
3	VSD controls	From VSD to burner	Plug & Play	YES
4	VSD power	From VSD to switch panel	10m cable pre-wired	YES
<b>RKB compact burner with LMV 26 integrated in burner housing</b>				
2	Gas train	From gas train components to burner	Plug & Play	YES
3	VSD controls	From VSD to burner	Plug & Play	YES
4	VSD power	From VSD to burner	3m cable pre-wired	YES
<b>RKB burner with LMV 51 integrated in switch panel</b>				
1	Switch panel	From burner terminal box to switch panel	Multiwire 12 x 0,75mm <sup>2</sup> (CC)	NO
2	Gas train	From gas train terminal box switch panel	Multiwire 25 x 0,75mm <sup>2</sup> (CC)	NO
3	VSD controls	From VSD to switch panel	Multiwire 8 x 0,75mm <sup>2</sup> screened cable without glands	NO
4	VSD power	From VSD to switch panel	Power cable, 3 phase + ground	NO
5	Air fan	From VSD to air fan	EMC cable with EMC gland on motor side, 3 phase + ground	NO
6	Servo motors	From air servo motor to switch panel	Supplied Siemens CAN-bus cable	YES
7	Speed sensor	From air fan terminal box to switch panel	3 x 0,75 mm <sup>2</sup> screened cable (CY)	NO
8	Flame guard	From burner terminal box to switch panel	3 x 0,75 mm <sup>2</sup> screened cable (CY)	NO
<b>Devices for all burners</b>				
9	Load control	PT1000 to burner switch panel	2 x 0,75 mm <sup>2</sup> screened cable (CY)	NO
10	Oil pump	From oil pump to switch panel	Power cable with gland on motor side, 3 phase + ground	NO
	Boiler safety	From low water device to switch panel	4 x 0,75 mm <sup>2</sup> screened cable (CY)	NO
	Max thermostat	From device to switch panel	4 x 0,75 mm <sup>2</sup> screened cable (CY)	NO

### 3. Plug-In terminal instruction

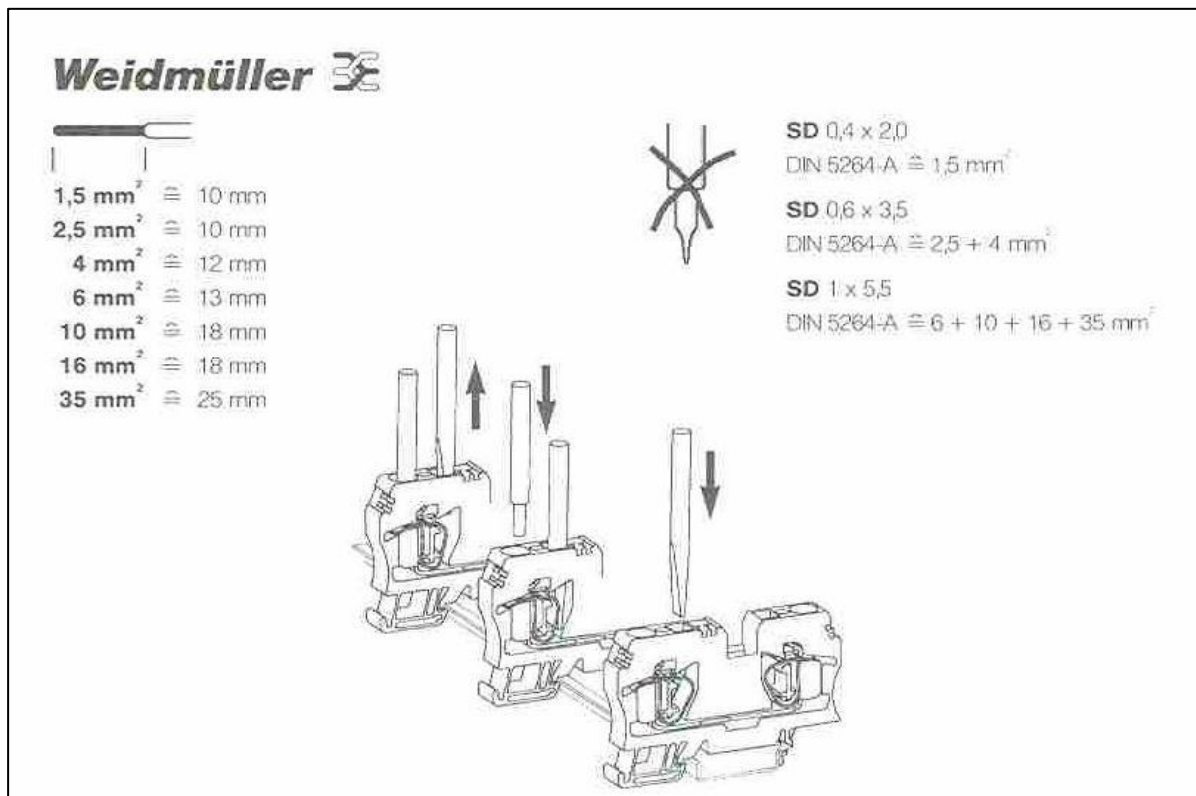

## 4. EMC gland instruction

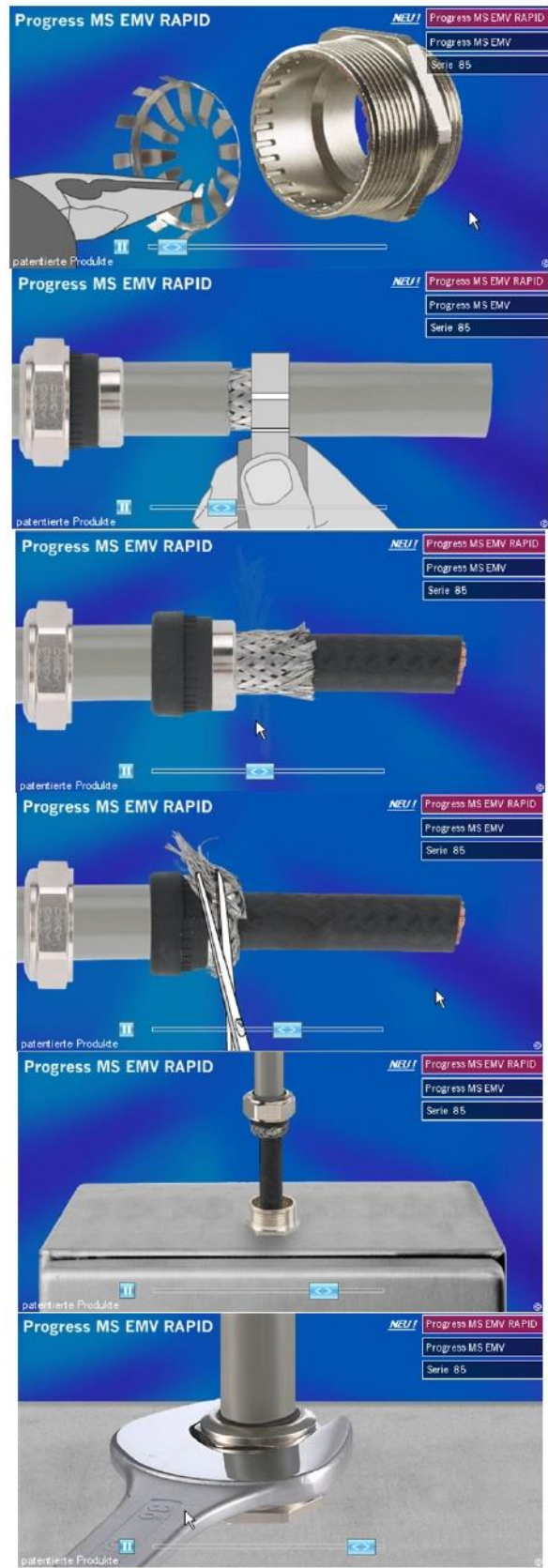
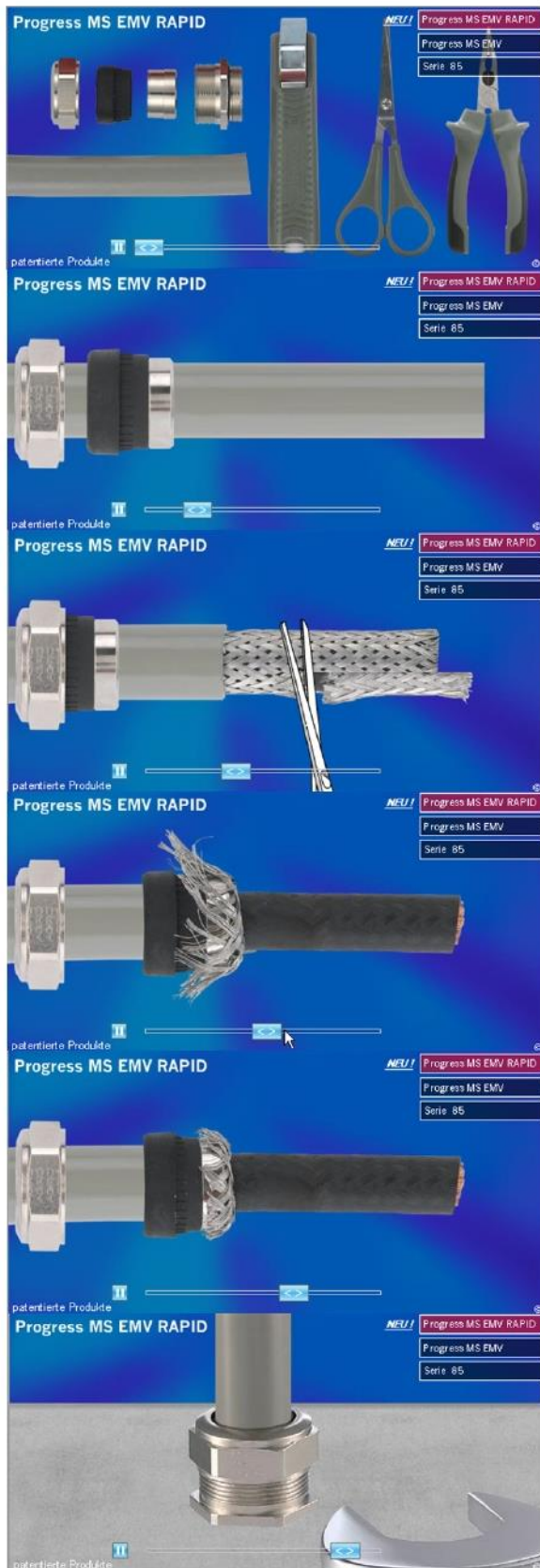

## 5. Cable and gland sizes for air fan motor

Fan Motor 380-400V/50Hz		EMC screened cable (mm <sup>2</sup> )	Frequency drive type Vacon 100	Gland holes in frequency drive
2800 rpm P (kW)	Current In (Amp)			
3,0	6,20	4x 1,5	V100 0008	2x M25
4,0	8,20	4x 2,5	V100 0009	2x M25
5,5	11,00	4x 2,5	V100 0012	
7,5	15,00	4x 6,0	V100 0016	
11,0	22,00	4x 6,0	V100 0023	
15,0	28,50	4x 10,0	V100 0031	
18,5	35,00	4x 10,0	V100 0038	
22,0	42,00	4x 10,0	V100 0048	
30,0	57,00	4x 16,0	V100 0061	
37,0	69,00	4x 25,0	V100 0072	
45,0	90,00	4x 35,0	V100 0087	

Fan Motor 208V/60Hz		EMC screened cable (mm <sup>2</sup> )	Frequency drive type Vacon100	Gland holes in frequency drive
3500 rpm P (kW)	Current In (Amp)			
3,0	12.90	4x 4,0	V100 0012	2x Ø37
4,0	15.90	4x 4,0	V100 0018	2x Ø37
5,5	22.20	4x 6,0	V100 0024	2x Ø37
7,5	29.60	4x 10,0	V100 0031	2x Ø37
11,0	42.10	4x 10,0	V100 0048	2x Ø37
15,0	55.60	4x 16,0	V100 0062	2x Ø37
18,5	68.30	3x25,0+16,0	V100 0075	2x Ø47
22,0	85.50	3x35,0+16,0	V100 0088	2x Ø47
30,0	110.00	3x50,0+25,0	V100 0105	2x Ø47
37,0	135.40	3x70+35,0	V100 0140	2x Ø59
45,0	165.00	3x95,0+50,0	V100 0170	2x Ø59

Fan Motor 380-480V/60Hz		EMC screened cable (mm <sup>2</sup> )	Frequency drive type Vacon 100	Gland holes in frequency drive
3500 rpm P (kW)	Current In (Amp)			
3,0	6.10	4x 1,5	V100 0008	2x Ø28,3
4,0	7.50	4x 1,5	V100 0009	2x Ø28,3
5,5	10.50	4x 2,5	V100 0012	2x Ø28,3
7,5	14.00	4x 4,0	V100 0016	2x Ø37
11,0	19.90	4x 6,0	V100 0023	2x Ø37
15,0	26.30	4x 10,0	V100 0031	2x Ø37
18,5	32.30	4x 10,0	V100 0038	2x Ø40
22,0	40.40	4x 16,0	V100 0048	2x Ø40
30,0	52.00	3x25,0+16,0	V100 0061	2x Ø40
37,0	64.00	3x35,0+16,0	V100 0072	2x Ø50
45,0	78.00	3x35,0+16,0	V100 0087	2x Ø50

<b>Fan Motor 575-600V/60Hz</b>		<b>EMC screened cable (mm<sup>2</sup>)</b>	<b>Frequency drive type Vacon 100</b>	<b>Gland holes in frequency drive</b>
<b>3500 rpm P (kW)</b>	<b>Current In (Amp)</b>			
3,0	4.70	4x 1,5	V100 0012	2x Ø37
4,0	5.70	4x 1,5	V100 0018	2x Ø37
5,5	8.00	4x 2,5	V100 0024	2x Ø37
7,5	10.70	4x 4,0	V100 0031	2x Ø37
11,0	15.20	4x 6,0	V100 0048	2x Ø37
15,0	20.10	4x 10,0	V100 0062	2x Ø37
18,5	24.70	4x 10,0	V100 0075	2x Ø37
22,0	30.90	4x 16,0	V100 0088	2x Ø37
30,0	39.80	3x25,0+16,0	V100 0105	2x Ø47
37,0	49.00	3x35,0+16,0	V100 0140	2x Ø47
45,0	59.70	3x35,0+16,0	V100 0170	2x Ø59

## 6. Cable and gland sizes for oil pump motor

<b>Oil pump motor 380-400V/50Hz</b>		cable (mm <sup>2</sup> )	Gland connection motor
<b>1450 rpm P (kW)</b>	<b>Current In (Amp)</b>		
0,37kW	1.1	4x 1,5	M20
0,55kW	1.6	4x 1,5	M20
0.75kW	1.9	4x 1,5	M20
1.1kW	2.6	4x 1,5	M25
1,5kW	3.6	4x 1,5	M25
2,2kW	5	4x 1,5	M25
3,0kW	6.6	4x 1,5	M25
4,0kW	8.5	4x 1,5	M32
5,5kW	11.3	4x 1,5	M32

<b>Oil pump motor 208V/60Hz</b>		cable (mm <sup>2</sup> )	Gland connection motor
<b>1750 rpm P (kW)</b>	<b>Current In (Amp)</b>		
0,37kW	1.9	4x 1,5	M20
0,55kW	3.1	4x 1,5	M20
0.75kW	3.8	4x 1,5	M20
1.1kW	6.7	4x 1,5	M25
1,5kW	9.6	4x 1,5	M25
2,2kW	12.7	4x 1,5	M25
3,0kW	16.3	4x 1,5	M25
4,0kW	20.8	4x 2,5	M32
5,5kW	22.1	4x 2,5	M32

<b>Oil pump motor 440-480V/60Hz</b>		cable (mm <sup>2</sup> )	Gland connection motor
<b>1750 rpm P (kW)</b>	<b>Current In (Amp)</b>		
0,37kW	0.9	4x 1,5	M20
0,55kW	1.5	4x 1,5	M20
0.75kW	1.8	4x 1,5	M20
1.1kW	2.4	4x 1,5	M25
1,5kW	3.2	4x 1,5	M25
2,2kW	4.5	4x 1,5	M25
3,0kW	6.0	4x 1,5	M25
4,0kW	7.7	4x 1,5	M32
5,5kW	10.5	4x 1,5	M32

<b>Oil pump motor 575-600V/60Hz</b>		cable (mm <sup>2</sup> )	Gland connection motor
<b>1750 rpm P (kW)</b>	<b>Current In (Amp)</b>		
0,37kW	0.7	4x 1,5	M20
0,55kW	1.1	4x 1,5	M20
0.75kW	1.4	4x 1,5	M20
1.1kW	1.8	4x 1,5	M25
1,5kW	2.4	4x 1,5	M25
2,2kW	3.5	4x 1,5	M25
3,0kW	4.6	4x 1,5	M25
4,0kW	5.9	4x 1,5	M32
5,5kW	8.0	4x 1,5	M32

## 7. Low water device SYR 2"

**LAAGWATER SYR 2" / LOWWATER SYR 2"  
LA SECURITE SUR 2" / WASSER MANGELN 2"**



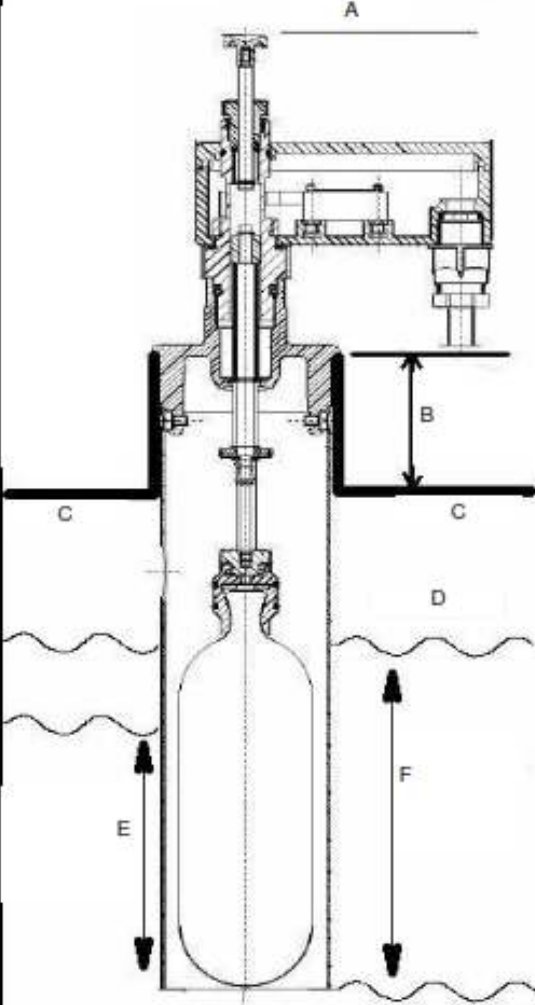

NL	
A	Testknop
B	SOK 2" Inwendig max. 25-30 mm
C	Ketellichaam
D	Waterniveau
E	Inschakelniveau 60 mm boven laagste waterniveau
F	Afchakelniveau 87 mm onder waterniveau

ENG	
A	Test Button
B	Socket 2" inside max. 25-30 mm.
C	Boiler
D	Water level
E	Switch on level 60 mm above lowest water level
F	Switch off level 87 mm below Water level

FR	
A	Bouton essais
B	Manchon 2" intérieur 25-30 mm max
C	Corps de la chaudière
D	Niveau d'eau
E	Niveau d'encenchement 60 mm au-dessus du niveau le plus bas
F	Niveau de d'enchenchement 87 mm en dessous du niveau haut

D	
A	Prüfstift
B	Stütze 2"innen 25-30mm
C	Kessel Körper
D	Wasserstand
E	Punkt zum einschalten 60 mm oben niedrigste Wasserstand
F	Punkt zum abschalten 87 mm unten Wasserstand

**NL**  
Laagwater direct in ketellichaam monteren. Beschermhuls mag nooit verwijderd worden. Laagste niveau moet zich minimaal 100 mm boven bovenkant bovenste vlampijp bevinden. Ontluchting mag nooit lager zitten dan de SYR 2"

**FR**  
La sécurité SASSERATH doit être montée dans le corps de la chaudière démontage de sa partie protection dans lequel travaille le flotteur. Le réglage du niveau bas min. Doit se trouver au moins 100 mm au-dessus du dernier tube de fumées. Le purgeur d'air ne doit se trouver à un niveau par rapport à la sécurité de niveau.

**ENG**  
Low water device has to be mounted straight in boiler. To be used always with covertube. Lowest level has to be min. 100 mm above the highest flametube of the boiler. Boiler bleed off device always higher then low water device SYR 2"

**D**  
Wassermangeln Sicherung direkt im Kessel Körper einbauen. Tauchhülse soll immer verwendet werden. Niedrigste Wasserstand soll minimal 100 mm oben Obenseite des Flammrohrs sich befinden. Euntlüftung darf sich nicht unter SYR 2" befinden.

### **Imprint**

All rights reserved, including the rights to the translations. Nothing from this issue may be copied, stored in an automatic data file or made public in any way or by any means, be it electronically, mechanically, photocopy or otherwise, without prior written consent from Zantingh B.V. Reprinting the document or any excerpt thereof, is forbidden. Changes, errors and misprints reserved. These assembly and operation instructions comply with the technical requirements at the time of printing. We reserve the right to implement technical and design changes.

## **Netherlands**

### **Zantingh B.V.**

Aarbergerweg 9, 1435 CA RIJSENHOUT  
Postbus 255, 1430 AG AALSMEER  
Netherlands  
Phone (+31) (0)297 - 219 100  
E-mail [info@zantingh.com](mailto:info@zantingh.com)  
Website [www.zantingh.com](http://www.zantingh.com)

## **France**

### **Zantingh France SARL**

95, rue F. de Lesseps  
F-44150 Ancenis  
France  
Phone (+33) (0)240 83 94 30  
E-mail [info@zantingh.fr](mailto:info@zantingh.fr)  
Website [www.zantingh.com](http://www.zantingh.com)

## **Mexico**

### **Zantingh México S.A. de C.V.**

Parque Industrial Benito Juárez  
Acceso III no.14  
76120 Querétaro  
Mexico  
Phone (+52) 422 209 50 60  
E-Mail [info@zantingh.mx](mailto:info@zantingh.mx)  
Website [www.zantingh.com](http://www.zantingh.com)