

Aarbergerweg 9
1435 CA Rijsenhout
P.O. Box 255
1430 AG Aalsmeer
The Netherlands
Tel. +31 (0)297 219100
www.zantingh.com
info@zantingh.com

OPERATING AND INSTRUCTION MANUAL

ZANTINGH FORCED GAS BURNER RKB – LMV5 & 7"-TOUCHSCREEN



ZANTINGH



YOU CAN COUNT ON OUR EXPERTISE

Dear Customer,

We would like to thank you for purchasing our product.

We provide this manual to ensure the distribution of all important information for your safety, optimal profit and product lifetime.

Please read the instructions carefully before installing or operating the product.

The safety and instructions in this manual must be followed to ensure that installation, commissioning, operation and maintenance are safe and in accordance to (local) standards and regulations..

Our technical department can provide additional information and support.

If you have any questions, please contact us.

Phone general: +31(0)297 – 219 100

Phone service: +31(0)297 – 219 125

+31(0)20 – 48 58 212 (*outside of office hours*)

E-mail: info@zantingh.com

CONTENTS

	Page
1. INTRODUCTION	4
2. DANGERS, WARNINGS AND NOTES OF CAUTION	5
3. TECHNICAL SPECIFICATIONS	8
3.1 Key to the model name:	8
3.2 Datasheet	9
4. SYSTEM COMPONENTS	10
4.1 Burner component	10
4.2 Air fan component	11
4.3 Gas train	11
4.4 Pilot gas line	13
4.5 Oil supply system	13
4.6 Control panel	13
5. OPERATION	15
5.1 Start sequence	15
5.2 Siemens burner control LMV5x	16
5.3 AZL display description and operation	17
5.4 Operation 7" touch screen with LMV5x	22
5.5 Switch from gas to oil and back	28
6. MAINTENANCE	30
6.1 Burner service term	30
6.2 Seasonal stop	31
6.3 Burner disposal	31
7. BURNER FAILURE REPORT	32
7.1 Troubleshooting	32
8. WARRANTY CONDITIONS	36

1. INTRODUCTION



IMPORTANT read this first!

The instructions are an integral part of the product. The instructions contain important information on the commissioning, usage and operation of the product. Please read the instructions carefully.

The guarantee becomes null and void if the mounting instructions are not followed. Zantingh B.V. cannot be held liable for these damages.

Store this manual carefully near the system!

A burner system is a combination of:

- **Electrical engineering**
- **Gas engineering**
- **Central heating engineering**
- **Measurement and control engineering**

A certified heating or electrical installer should instal the product, in accordance with the applicable (local) standards and regulations.

In Europe the applicable requirements are specified in:

- EN 676: general requierments for the construction and operation of gas burner systems;
- NEN 1010: electrical installations for low-voltage;
- NEN 1078: requirements for gas installations $\leq 500\text{mbar}$;
- NEN 2078: requirements for industrial gas installations;
- NEN 3028: requirements for fuel combustion installations;
- As well as possible local regulations.

Commissioning a Zantingh burner ought to be performed with the utmost precision and by Zantingh authorized personnel. Any commissioning work or change of settings of the burner system by somebody other than by the people mentioned above, can lead to a dangerous situation and have consequences on product liability and warranty.

Changes to the burner system may only be implemented conform instructions after receiving confirmation in writing from Zantingh.



REMARK:

Take care of your burner system as if it is the heart of your company. Restrict authorization to trained personnel only. Please contact your Zantingh representative or local service department in case of doubt.

2. DANGERS, WARNINGS AND NOTES OF CAUTION

NOTE: The information included in this section is dedicated to both user and personnel charged with installation and/or maintenance

Always make sure that a copy of this manual is available in the boiler room.



In case of fire or any other emergency:

When accessible close the gas valve (A1) of the gas train and switch off the main switch on the burner panel.

When there's a fire in the boiler room you need to switch off the electric power using the "fire switch" mounted on the wall outside the boiler room.

Before you start

- The equipment must be installed by qualified personnel following the manufacturer's instructions, in compliance with the regulations in force.
- Qualified personnel means those having technical knowledge in the field of civil or industrial heating systems, electrical systems and are preferably employed by service centers authorized by the manufacturer.
- The equipment should be installed in a suitable boiler room, with ventilation openings that are sufficient to ensure a good combustion and are in compliance with the regulations in force.
- Before installing the equipment, make sure that the equipment rating (see equipment's name plate) is the same as delivery mains (electricity, gas or other fuel).
- Improper installation may cause injury to people and animals or damage to property, for which the manufacturer cannot be held liable.
- Remove all packaging material and inspect the equipment for integrity. In case of any doubt, do not use the equipment, but contact the supplier instead. The packaging materials (wooden crate, nails, fastening devices, plastic bags, foamed polystyrene, etc.), should not be left within the reach of children, as they may prove harmful.
- The equipment should be used exclusively for which it was designed. Any other use shall be considered as improper and therefore dangerous.
- Only equipment designed according to the regulations in force should be used.
- Failure to comply with the above instructions is likely to impair the equipment's safety.

Special instructions with regard to electric power

- The equipment must be installed and efficiently earthed as required by current safety regulations.
- It is vital that all safety requirements are met. In case of any doubt, ask for an accurate inspection of electrics by qualified personnel. The manufacturer cannot be held liable for damages that may be caused by failure to correctly earth the equipment.
- Do not use gas pipes to earth electrical equipment.

- Qualified personnel must inspect the system to make sure that it is adequate to take the maximum power used by the equipment as shown on the equipment's name plate. In particular, make sure that cable cross section of power cables are adequate for the power used by the equipment.
- No adaptors, multiple outlet sockets and/or extension cables are allowed to connect the equipment to the electric mains.
- The use of any power-operated components implies observance of a few basic rules, for example:
 - do not touch the equipment with wet or damp parts of the body and do not work on the equipment on bare feet;
 - do not pull electric cables;
 - do not leave the equipment exposed to weather conditions (rain, sun, etc.) unless expressly required to do so;
 - do not allow children or unexperienced persons to use or work on the equipment;
- The electric cables shall not be replaced by the user. In case of damage to a cable, switch off the unit and contact qualified personnel to replace it.
- When the equipment is to remain idle or not in use for some time, the electric switch supplying all the power-driven components in the system (i.e. pumps, burner, etc.) should be switched off.

Special warnings regarding fuel supply

- Before installation, it is recommended that all fuel supply lines be carefully cleaned inside, to remove foreign matter that might impair the burner operation.
- Before the burner is commissioned, have qualified personnel inspect the following:
 - all connections of the fuel supply system are tight and properly sealed;
 - the fuel supply flow rate matches the firing rate required for the burner;
 - the burner combustion system is designed for the available fuel type;
 - the fuel supply pressure matches the one on the name plate;
 - the dimensions of the fuel supply system are adequate to the burner firing rate, and the system is equipped with all the safety and control devices required by the regulations in force;
 - the boiler room ventilation openings are sufficient to ensure a good combustion and are in compliance with the regulations in force.
- Do not obstruct the ventilation openings of the room where gas fired equipment is installed. This might result in dangerous conditions such as the development of toxic or explosive gas composition.
- When the burner is to remain idle or not in use for some time, or in case of prolonged absence of the user, the fuel supply valves should be closed.



Precautions if you smell gas:

1. Immediately open doors and windows to create an air flow to purge the room
2. Close the gas valves
3. Do not operate electric switches, the telephone, or any other item likely to generate sparks
4. Contact qualified personnel

Instructions regarding operation and maintenance

- The equipment shall be operated and serviced by qualified personnel only and in compliance with the regulations in force.
- Make sure that the burner system has been firmly secured to the boiler.
- Make sure that inlet or exhaust grilles are unobstructed.
- Before commissioning the burner system and thereafter at least once a year, have qualified personnel perform the following operations:
 - set the burner fuel flow rate depending on the capacity of the boiler;
 - set the combustion air flow rate to obtain the best possible efficiency;
 - check the system operation for proper combustion, to avoid any excess harmful or polluting gases regarding the regulations in force;
 - make sure that control and safety devices are working properly and mechanical locking devices of controls have been duly tightened;
 - make sure flues are in good condition and not leaking;
- To ensure equipment efficiency and proper operation, it is essential that maintenance operations are performed by qualified personnel at regular intervals, following the manufacturer's instructions.
- Before any cleaning or servicing operation, disconnect the system from the power mains by turning the master switch OFF, and cut off the fuel supply by closing the hand gas valve A1.
- Observe caution with hot burner components. They become hot during operation and will remain hot for some time after the burner has stopped.
- In case of a burner shut-down, reset the control box by means of the RESET pushbutton. If a second shut-down takes place, call the service department, without again trying to RESET.
- In case of breakdown and/or defective operation, shut off the system from fuel and electrics. Make no attempt to repair the equipment or take any other action. Contact qualified personnel instead.
- Equipment shall be repaired exclusively by a servicing center, duly authorized by the manufacturer, with original spare parts and accessories.
- When a decision is made to discontinue the use of the equipment, those parts likely to constitute sources of danger shall be made harmless.
- In case the equipment is to be sold or transferred to another user, or in case the original user should move and leave the unit behind, make sure that these instructions accompany the equipment at all times so that they can be consulted by the new owner and/or the installer.



LIABILITY:

The manufacturer shall not be held liable, by agreement or otherwise, for damages resulting from improper installation, use and failure to comply with the instructions supplied by the manufacturer. The occurrence of any of the following circumstances may cause explosions, polluting gases (example: carbon monoxide CO), burns, serious harm to people, animals and things:

- Failure to comply with one of the instructions in this chapter.
- Incorrect handling, installation, adjustment or maintenance.
- Incorrect use of the equipment or incorrect use of its parts or optional supply.

3. TECHNICAL SPECIFICATIONS

To understand this manual better you need to know which type of burner has been installed (TR or RKB) and which type of system it controls. This information is provided on the name plate on the right-hand side of the burner.



ZANTINGH

Zantingh B.V.
Aarbergerweg 9
1435 CA Rijsenhout
P.B. 255, 1430 AG Aalsmeer
Telefoon (+31)(0)297-219 100
Telefax (+31)(0)297-219 199
E-Mail info@zantingh.com

SERIAL NR.	: 24-24-2402401
PROJECTNUMBER	: 23000
TYPE	: RKB 10.0 ND-HO M GO /T
NOX CATEGORY	: 3
BUILT /MONTH	: 2024/08
BURNER CAT.	: B23
QMIN/QMAX kW(Hi)	: 1600/12950 kW
FUEL	: G20/Oil
GASPR.MIN/MAX	: 185/250 mbar
GAS/OIL FAMILY	: I2H/ASDM D-240
VOLTAGE	: 230/1~N/400/3~/50Hz/IP40
E - CONSUMPTION	: 40,12kW / 74,8 A
IP CLASS	: IP40
PIN NUMBER	: 1312DO6737
DESTINATION	: GB



1312/24

CAUTION HIGHTENSION!
BURNER MUST BE INSTALLED IN CONFORMITY
WITH THE LOCAL PROVISIONS.
FOR USE IN ADEQUATE VENTILATED AREAS
ONLY.
READ INSTRUCTIONS BEFORE USE.



For the following information please refer to the name plate:

- serial number
- type and model of the burner
- month, year and county of manufacture
- gas pressure
- electrical power consumption and supply.

The burner type and serial number should always be reported in communication with the supplier

3.1 Key to the model name:

Key - clé - sleutel:	
TR-RKB	: air casing type - type caisse d'aire - type luchtkast
1.0-18.0	: indication output combustion chamber - indication puissance chambre de combustion - indicatie vermogen vuurhaard
ND	: indication NOx emission - indication émission NOx - indicatie NOx emissie
DKR-HO	: mixing design type - type construction de mélange - type meng-inrichting
P-M	: gas/air ratio adjustment; P = pneumatic, M = electronic – réglage ratio gaz/air; P = pneumatique, M = électronique gas/lucht verhoudingsregeling; P = pneumatisch, M = elektronisch
G-GO	: fuel; G = gas, GO = gas/oil - combustible; G = gaz, GO = gaz/fioul - brandstof; G = gas, GO = gas/olie
/T	: reference CE file - référence dossier CE - referentie CE dossier

3.2 Datasheet

Burnertype	output range - gas		output range - oil		Furnace back press. *(mbar)	Gas pressure range ** (mbar)	Electrical consumption		Sound level dB(A) ***
	Min kW	Max kW	Min kW	Max kW			Airfan kW	Oilpump kW	
TR 1.0 ND_._.M.G/O	350	1.264	337	1.011	10,0	85 - 300	3,0	0,55	73,0
TR 1.5 ND_._.M.G/O	350	1.896	506	1.517	10,0	85 - 300	4,0	0,55	73,0
TR 2.0 ND_._.M.G/O	350	2.528	674	2.022	10,0	85 - 300	5,5	0,75	73,0
RKB 2.5 ND_._.M.G/O	630	3.152	841	2.522	10,0	185 - 300	5,5	0,75	75,3
RKB 3.0 ND_._.M.G/O	759	3.793	1.011	3.034	11,5	185 - 300	7,5	0,75	76,8
RKB 3.5 ND_._.M.G/O	885	4.424	1.180	3.539	11,5	185 - 300	11,0	0,75	75,0
RKB 4.0 ND_._.M.G/O	1.011	5.054	1.348	4.043	11,5	185 - 300	11,0	0,75	75,0
RKB 5.0 ND_._.M.G/O	1.053	6.315	1.684	5.052	11,5	185 - 300	11,0	1,5	78,7
RKB 6.0 ND_._.M.G/O	1.264	7.582	2.022	6.066	11,5	185 - 300	15,0	1,5	78,0
RKB 7.0 ND_._.M.G/O	1.475	8.848	2.359	7.078	11,5	185 - 300	18,5	2,2	78,7
RKB 8.0 ND_._.M.G/O	1.680	10.103	2.694	8.082	12,5	185 - 300	22,0	2,2	83,7
RKB 9.0 ND_._.M.G/O	1.900	11.377	3.034	9.102	13,5	185 - 300	30,0	2,2	81,8
RKB 10.0 ND_._.M.G/O	1.900	12.641	3.371	10.113	15,5	185 - 300	37,0	2,2	84,6
RKB 12.0 ND_._.M.G/O	2.200	15.169	4.045	12.135	15,5	185 - 300	45,0	3,0	85,3
RKB 14.0 ND_._.M.G/O	2.500	17.698	4.719	14.158	17,5	185 - 300	75,0	3,0	85,3
RKB 16.0 ND_._.M.G/O	2.800	20.226	5.394	16.181	17,5	185 - 300	95,0	4,0	85,3
RKB 18.0 ND_._.M.G/O	3.000	22.754	6.068	18.203	19,5	185 - 300	110,0	5,5	85,3

* Negative back pressure in the boiler is not allowed

** All values for the gas circuit are valid for methane gas G20 according to EN 437 (at atm pressure 1.013 mbar and temperature 15 ° C)

*** Noise measured at a distance of 1 m from the burner body (EN ISO 3744)

4. SYSTEM COMPONENTS

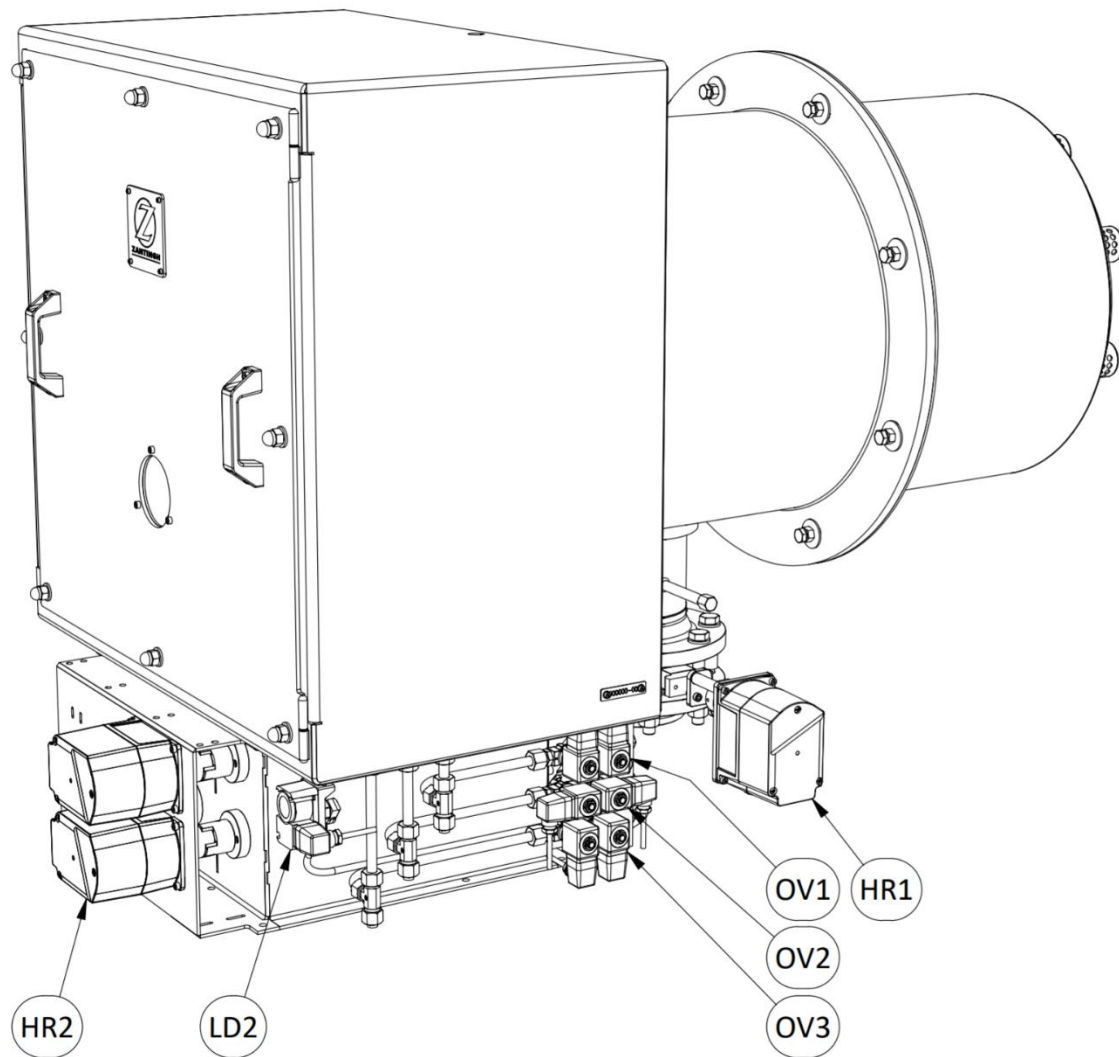

4.1 Burner component

The burner component is in welded steel-plated housing. Under the burner housing there's an air valve section, it controls the air supply to the burner. A servomotor drives the valves. The load controller or burner controller controls the servomotor. The combustion air level is measured and monitored using air-pressure switches (LD2). If you have a burner type TR the pressure switches are located on the upper side of the burner. If you have a burner type RKB the switches are mounted under the burner housing. The primary and secondary burner combustion devices are situated in the cylindrical part of the burner. The flame monitoring device is mounted on the side of the cylindrical part. The pilot burner is positioned at the centre of the burner head. The pilot burner includes an electrical ignition. A high-voltage transformer is included in the burner housing for electrical ignition. The gas supply connection to a servomotor-driven gas quantity control valve is located under the cylindrical part of the burners.

4.2 Air fan component

The air fan is positioned under the burner. The air fan supplies the required combustion air. This air fan has a directly coupled and balanced fan wheel. The fan wheel is driven by an electromotor. The air fan of a TR burner is directly connected to the air-valve section. The air fan of an RKB burner is separate and stands on the floor.

The connection is made using a flexible sleeve. Vibration isolators are used when mounting the air fan on the floor. An electrical circuit in the burner control panel and the frequency controller provide the variable speed of the electromotor. The air fan can, therefore, provide the required air quantity based on the measured air quantity. The standard air fan includes an inlet grid to prevent coming into contact with moving parts. A plate silencer is provided on the air fan inlet for noise reduction purposes. Cylindrical noise silencers are available as an option.

Frequency control

A circuit in the control panel controls the air fan electro motor. A frequency control unit, not included on the control panel, controls the air fan rotational speed based on the burner load. The speed is controlled directly from the burner control unit by sending a 0-10 V/4-20 mA signal to the frequency control unit.

Common settings:

Frequency for low flame approx. 25 Hz (= ± 1400 cycles).

Frequency for high flame approx. 50 Hz (= ± 2800 cycles).

4.3 Gas train

The gas train controls the gas supply from the distribution network. Several monitor and control units are mounted on the gas train to control the burner gas supply.

The maximum supply pressure for the system is indicated on the burner nameplate.

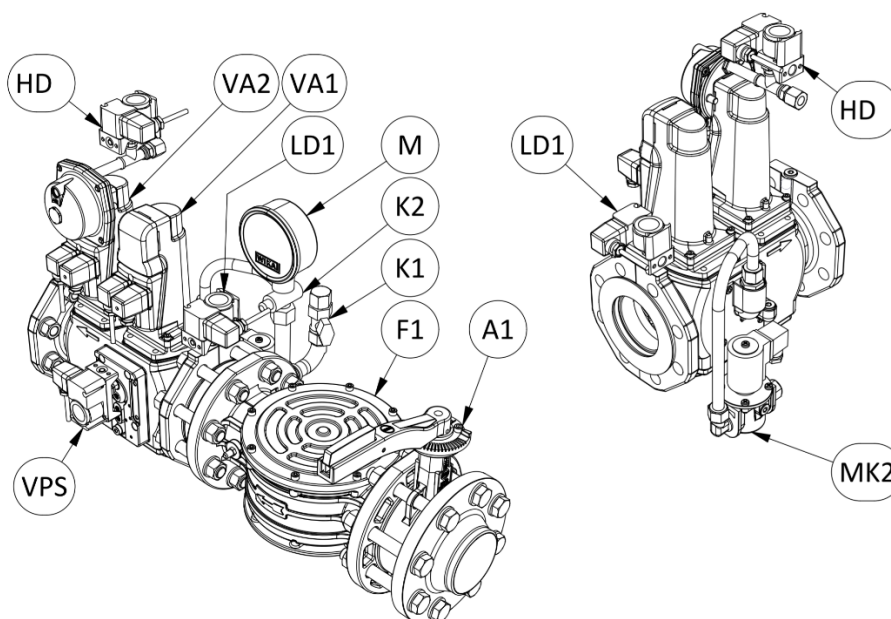

Shut-off valve (pos. A1)

The shut-off valve (A1) shuts off the gas supply to the burner system in case of:

- Fire or other emergencies.
- Maintenance work on the gas train equipment.
- Leakage of or between parts after the valve.
- Shutting down the burner system for a long period of time.

Filter (pos. F1)

The filter (F1) prevents dirt and welding globules from the gas supply line from getting into the equipment of the gas train. This protects the equipment from damage caused by contamination.

Safety valves (pos. VA1 and VA2)

These safety valves automatically open/close the gas supply to the burner. Two gas safety valves (VA1 + VA2) are used for safety reasons.

The second safety valve (VA2) has an integrated gas pressure regulator that makes sure the gas pressure on the burner head is constant.

Valve proving system (pos. VPS)

A pressure sensor (VPS) measures the gas pressure between the two safety valves VA1 and VA2 during the start sequence of the burner, to make sure they are gas tight. When leakage is detected the burner will lockout.

The Valve Proving System works according to the following operation sequence:

1. VA2 (burner side) opens to effectuate an atmospheric pressure between the safety valves.
2. VA2 closes. The pressure must stay below the setpoint of the pressure sensor (VPS) during a pre-set time, indicating the gas tightness of VA1.
3. VA1 (supply side) opens to effectuate a pressure between the two safety valves equal to the gas supply pressure.
4. VA1 closes. The pressure must stay above the setpoint of the pressure switch (VPS) during a pre-set time, indicating the gas tightness of VA2.

Minimum gas pressure safety device (pos. LD1)

The pressure switch (LD1) is activated when the main gas pressure reaches under the minimum limit value. The setting value is determined during the commissioning of the burner.

Maximum gas pressure safety device (pos. HD)

The HD pressure switch monitors the maximum burner/boiler capacity and is mounted on the burner head to control the burner load by means of air pressure. The settings of the pressure switches is determined when commissioning the burner system.

Manometer (pos. M) and push button valve (pos. K2)

Press the push button valve to read the supplied inlet pressure on the manometer.

4.4 Pilot gas line

Shut-off valve (pos. K1)

The ball valve (K1) is used to bleed the gas supply line. The bleed line has to include a separate pipe through the roof to the outside air. The opening has to be protected against contamination, dirt and rain. Plug off the ball valve if there is no bleeding line.

Pilot gas solenoid valve (pos. MK2)

The pilot gas solenoid valve automatically opens or closes the gas supply to the pilot burner.

4.5 Oil supply system

When not specifically stated otherwise, the burner is made for oil as emergency fuel only, with high/low controls. The burner is capable of oil firing during 2x24 hours maximum. If the burner is equipped for oil firing, it comes with a two or three nozzle (stage) oil combustion system, depending on the capacity of the burner. It is mounted in the burner component (head).

At ignition the oil pump is activated and the valves to the first nozzle are open. An electrical spark is used for the ignition. According to the requested burner load the valves to the 2^e and 3^e nozzle will be opened.

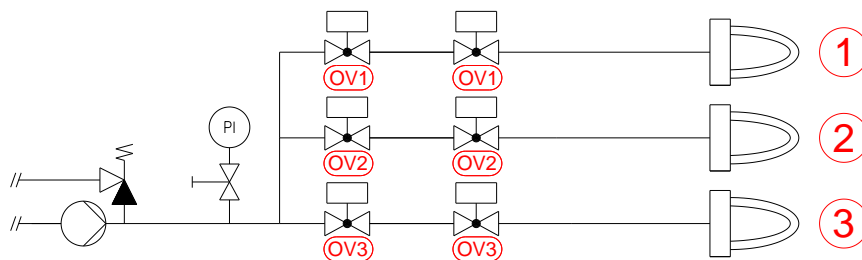

4.6 Control panel

The control panel includes all electrically controlled operation, monitoring and control units of the burner, air fan, gas train, boiler and other secondary connected devices. The electric circuits of all devices and units are connected to the control panel in such a way that the total system can operate safely.

These circuits can be classified into the following main groups:

- Boiler/safety circuit.
- Thermostat (start) circuit.
- Burner control.
- Load control.
- External control (Fiduface).
- Failure indicator lights.
- Motor groups/fuses.
- Control switches and reset buttons.
- Optional CO₂-circuit and CO-detector circuit.
- Condenser alarm.

Control switches and reset buttons

The control panel includes a few switches and press button valves:

- Fire on/off switch.
- Selector switch for load control with the following two options:
 - 1 = Automatic, modulated by load controller.
 - 2 = External, the burner load and on/off status is controlled by the climate or process computer.
- Reset, resets all failures.

The following control panel switches are optional:

- Selector switch gas/oil.
- Selector switch heat/steam.
- CO₂ dosing on/off.
- Flue gas valve open/closed.

5. OPERATION

5.1 Start sequence

When the gas pressure is nominal, the correct power is supplied to the control panel, the safety valves are closed, the on/off thermostat emits an “on” signal and all other boiler values are within the limits, the burner will start when the burner on/off switch is set to 1.

The start-up sequence is as follows:

- A.** After switching the system to “ON”, the air fan starts at low speed, sometimes after a short delay.
- B.** Once the air fan is at nominal speed, the servomotor of the air quantity control valve (pos. HR2) opens fully. When the servomotor that controls the air quantity control valve doesn't make the complete pre-set stroke, the air quantity control valve will not be sufficiently opened. The burner will be shut off and the system goes into lockout. An error message is displayed. The air fan will be set to maximum speed (50 Hz) approximately linear to the air valves to ventilate the system.
- C.** If the air quantity control valve is opened the pre-purge cycle starts. During the 30 seconds pre-purge cycle the boiler furnace is ventilated, to clear any remaining flue gas. During the pre-purge cycle the position of the air quantity control valve and of the air pressure are checked continuously.
- D.** At the end of the pre-purge cycle the air fan is set to low speed (+/- 25 Hz) and the air quantity control valve is positioned to the start/low flame position. The gas quantity control valve (pos. HR1) controlled by a servomotor is also positioned to the start/low flame position. The minimum air pressure is checked during operation by a second air pressure switch (pos. LD2 low).
- E.** All the air and gas controls are now in the start position. The next step is to light the pilot flame. A few seconds after reaching the start position the ignition transformer is switched on. It makes an electrical spark between the ignition electrodes.
- F.** After three (3) seconds the pilot gas valve (pos. MK2) opens and the spark lights the gas. After another five (5) seconds the flame monitoring device checks whether the UV scanner detects a pilot flame. The 5 seconds period during which the pilot flame is lighted is called the first safety time. At the end of the first safety time the pilot flame should be burning stable and the electrical spark is switched off. The flame monitoring unit checks the flame continuously during operation. If the flame is not formed in the first safety time the flame monitoring unit goes into lockout and an error message is displayed on the electronic module.

- G.** If the flame monitoring unit detects the pilot flame, the system continues the ignition procedure after a short time period. The main safety valves (pos. VA1 and VA2) open to ignite the main flame. The pneumatic gas pressure regulator, which is mounted on the second safety valve (pos. VA2), makes sure the correct output gas pressure for the burner load is obtained.

Five (5) seconds after opening the safety valves the pilot gas is shut off. The main flame has to be stable, it is checked by the flame monitoring unit continuously. The 5 seconds during which the pilot valve (pos. MK2) and the main valves (pos. VA1 and VA2) are in the open position, is called the second safety time. If the flame is not formed within this time the flame guard goes into lockout and an error message is displayed on the electronic module.

The minimum gas pressure switch (pos. LD1) monitors the supply gas pressure continuously at the lowest applicable level.

- H.** After the main flame has formed and the start sequence of the burner control panel is successfully gone through, the burner is “in operation” on low flame. Approx. 35 seconds after opening the main valves the load controller starts setting the load.
- I.** If the load control switch on the control panel is set to 1 Auto, the burner load and switching on and off will be controlled by the load control unit. The maximum gas pressure switch (pos. HD) monitors the maximum burner load by measuring the gas pressure.

5.2 Siemens burner control LMV5x

The LMV5 is a microprocessor-based burner management system with matching system components for the control and supervision of forced draft burners of medium to high capacity.

The following components are integrated in the LMV5:

- Burner control with gas valve proving system
- Electronic fuel-air ratio control
- PID temperature or pressure controller (boiler controller / load controller)
- Variabel speedrive (VSD module)

The system components are interconnected via a bus system. Communication between the bus users takes place via a safety-related, system-bound data bus (for safety reasons, integration of the bus into external CAN bus systems is not possible). All safety-related digital outputs of the system are permanently monitored via a contact feedback network.

Basicdiagram

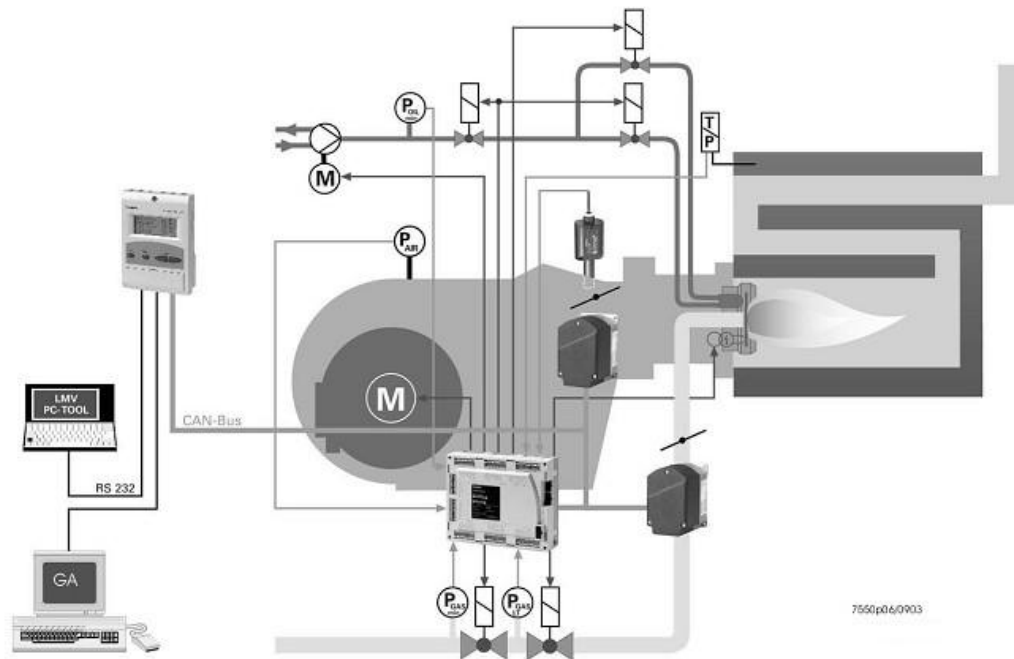

Example: Dual Fuel burner

- Gas: Modulating
- Oil: 2-stage

5.3 AZL display description and operation

The LMV5 is operated and programmed with the help of the AZL5 or with the touchscreen.

The AZL5 with LCD clear text and menu-driven operation affords straightforward operation and targeted diagnostics. For making diagnostics, the LCD shows the operating states, the type of fault and the point in time the fault occurred.

The parameter setting levels for the burner / boiler manufacturer and heating engineer are password-protected to prevent unauthorized access. Basic settings that the plant operator can make on site do not require a password.

In case of failure, before resetting, write down the text/code which appears in the display of the AZL unit. See "Display and error messages" (separate AZL manual).

Please also write down the burner type and manufacturing year. Please contact our service department. They will first attempt to solve the problem via the telephone call.

Display and settings

Menu structure:

Main menu level

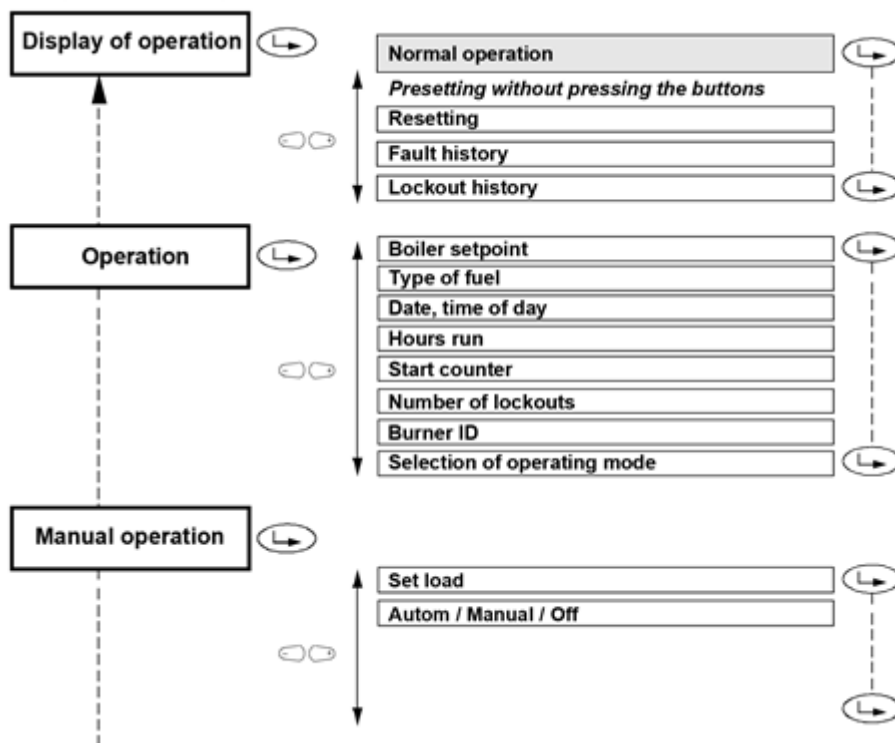

Description of the buttons and display

Legend for operation AZL5

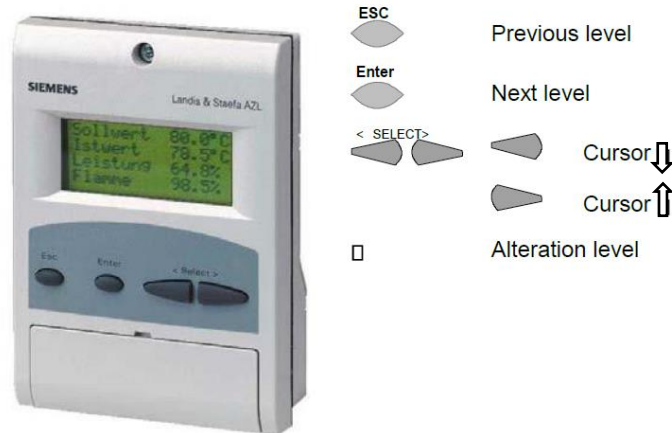

Setpoint change

The end user is allowed to change a number of settings in the display of the LMV. This text contains information about these changes.

Press the buttons < and > + ENTER to read and to select values.

The arrow buttons < and > can be used to change the setpoint value (required boiler temperature in °C).

Main menu:

```
<
Display of current functioning level
<
Operation → Setpoint → Setpoint W1 → Act.: 80
                                           Nw.: 80
```

Set the new value with the buttons < and >. Press ENTER to confirm the value.

Change maximum load

```
Operation → User Max Load → User MaxLoadMod → Act.: 100
                                                    Nw.: 100
```

Set the new value with the buttons < and >. Press ENTER to confirm the value.

Temperature settings

Check the maximum operating temperature before you enter changes. When the temperature is too high the maximum limit thermostat will activate a lockout.

Default settings for the LMV:

Setpoint plus 6 degrees Celsius; burner stops.

Setpoint minus 2 degrees Celsius; burner start.



IMPORTANT:

The setpoint for boiler temperature when oil firing should never be below 70°C.

Display of normal operation

Below, the most important displays of normal operation and examples of *Lockout and start prevention messages* and *Parameterization* are defined. In normal operation, the display shown is the default display which automatically appears and which is maintained as long as no settings are made and no unusual events like faults or start preventions occur.

The change from other displays to the normal display can be made by pressing the **Info** button.



IMPORTANT:

For a detailed description and service of the error and diagnosis codes, please refer to the annex AZL user interface.

HOMERUN (Phase 10)

L	M	V	5	x						
H	o	m	e	R	u	n				1 0
S	t	a	r	t	N	o	1	2	3	4 5 6
F	0	5	.	1	A	0	2	.	4	0 4 . 3

STANDBY (Phase 12)

S e t p o i n t	1 2 5 ° C
A c t V a l u e	1 2 4 ° C
F u e l	O i l
S t a n d b y	1 2

Example: Display of lockouts in the lockout history

In the event lockout occurs, the display alternates at 5-second intervals. Press **Enter** to select 1 of the 2 display texts. In that case, the alternating cycle is interrupted.

Example: Lockout due to a gas pressure signal in connection with gas valve proving.

1	1 8 . 0 6 . 9 9	1 0 : 3 5
C :	3 1	D : 0 0 P : 8 1
S t a r t	N o :	1 2 3 4 5 6
L o a d :	2 5 . 0	G a s

G a s	P r e s s u r e
V a l v e	P r o v i n g :
V a l v e	o n G a s
S i d e	l e a k i n g

C = error code

D = diagnostics

P = phase

DK = gas valve proving

Example: Display of errors in the error history

In contrast to the lockout history, the error history contains the errors of all error classes and not only the lockouts.

If an error occurs, the display alternates at 5-second intervals.

1 2	C l a s s :	0 3	G A S
C o d e :	2 1	P h a s e :	2 4
D i a g :	0 0	L o d :	0 . 0
S t a r t	N o :	1 2 3 4 5 6	

Example: Safety loop

open

S a f e t y L o o p	o p e n
---------------------	---------

Lockout and error messages

Example: Immediate display of lockouts

In the event lockout occurs, the display alternates at 5-second intervals.

L o c k o u t

G a s P r e s s u r e w
V a l v e P r o v i n g :
V a l v e o n G a s
S i d e l e a k i n g

Example: Immediate display of safety shutdowns

In the event of safety shutdown, the display alternates at 5-second intervals.

S a f e t y S h u t d o w n

G a s P r e s s u r e h a s
d r o p p e d b e l o w
m i n i m u m L i m i t

Example: Immediate display of warnings

In the event of warnings, the display alternates at 5-second intervals.

W a r n i n g

S l o p e t o o s t e e p

Example: Immediate display of start preventions

In the event of start preventions, the display alternates at 5-second intervals.

S t a r t P r e v e n t i o n

Air Pressure on

5.4 Operation 7" touch screen with LMV5x

The Siemens touch screen is a digital display with status of the connected circuits (boiler safeties) and burner status.

Home

The main screen displays current information. No safety related settings can be changed.

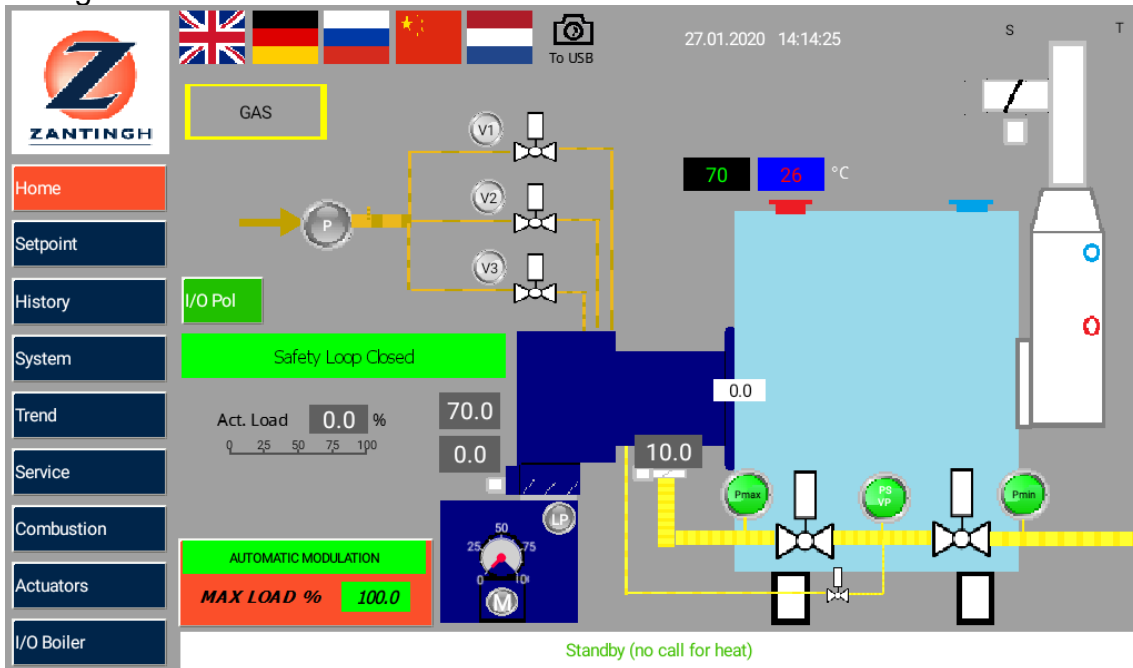

Menustructure:

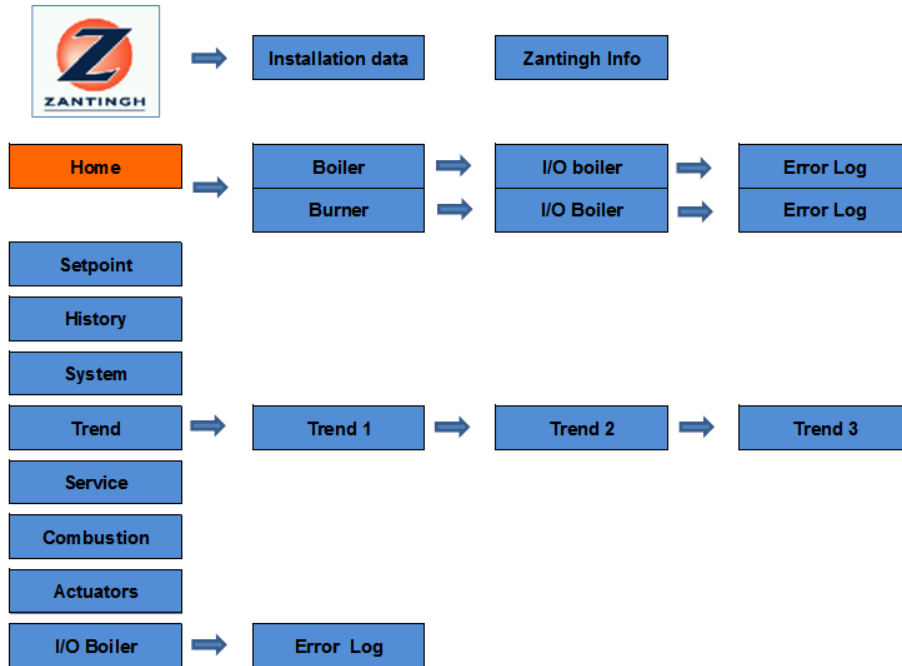

Pressing the boiler will give access to the actual system status. Green is functional, red is fault/error.



Pressing one of the menu items displays the error history.

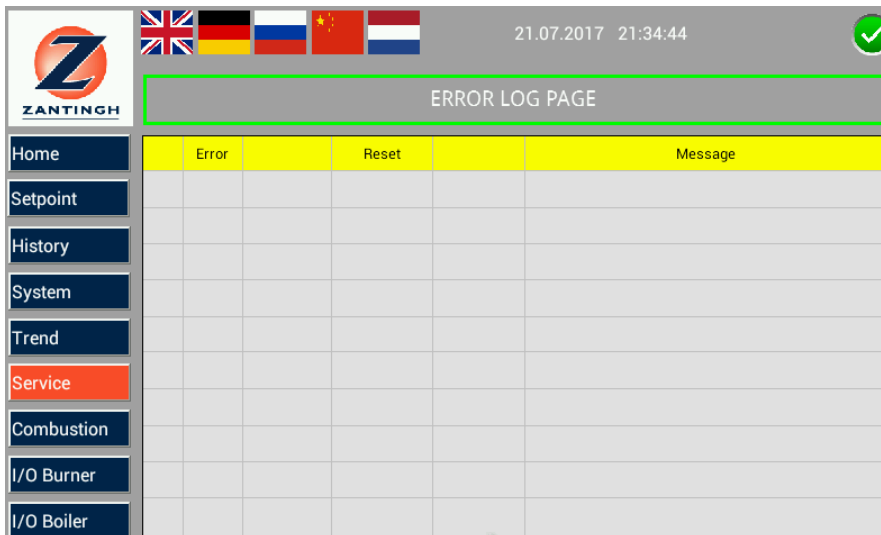

Pressing the burner image in the Home screen displays the burner error log.

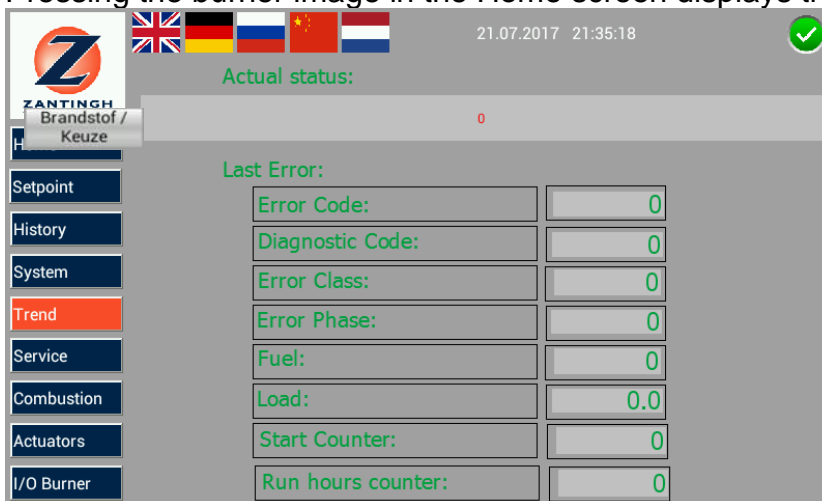

Setpoint/Actual

Display of actual value and setpoint.

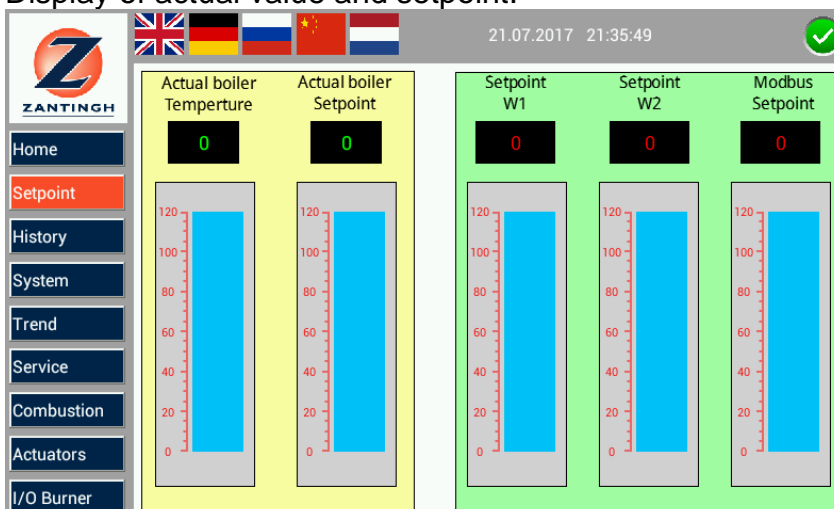

Log

Display of error and error history. Important error codes for diagnoses.

The screenshot shows the Zantingh Log page. At the top, there are flags for the UK, Germany, Russia, China, and the Netherlands, along with the date and time: 21.07.2017 21:36:14. A green checkmark is visible in the top right corner. The page features a sidebar with navigation options: Home, Setpoint, History (highlighted), System, Trend, Service, Combustion, Actuators, and I/O Burner. The main content area is divided into two sections: Lockout History and Error History. Both sections display a table with columns for Error Code, Diag Code, Error Class, Error Phase, Fuel, Load, Startup total, and Hours run counter. The Lockout History table shows two rows of data, both with values of 0. The Error History table shows two rows of data, also with values of 0. A dropdown menu with '-1' is visible next to the 'Last' entry in both tables.

System

Display of most important system data.

The screenshot shows the Zantingh System page. At the top, there are flags for the UK, Germany, Russia, China, and the Netherlands, along with the date and time: 21.07.2017 21:36:44. A green checkmark is visible in the top right corner. The page features a sidebar with navigation options: Home, Setpoint, History, System (highlighted), Trend, Service, Combustion, Actuators, and I/O Burner. The main content area displays several key system parameters in a grid layout: LMV ASN (LMV date: 0-0-0 0, Release: 0, LR: 0), AZL ASN (AZL date: 0-0-0 0, Release: 0), System operating hours (0), Startup counter (0), Burner identification, and Service information (Zantingh B.V., Aarbergerweg 9, 1435 CA Rijsenhout, T +31 297 219100, F +31 297 219199, E info@zantingh.com). A footer note reads: AZT7 LMV5 Application Zantingh VSJVV 01-06-2017.

Service

Display of memo's/remarks from engineers.

The screenshot shows the Zantingh Service page. At the top, there are flags for the UK, Germany, Russia, China, and the Netherlands, along with the date and time: 21.07.2017 21:37:12. A green checkmark is visible in the top right corner. The page features a sidebar with navigation options: Home, Setpoint, History, System, Trend, Service (highlighted), Combustion, Actuators, and I/O Burner. The main content area displays a table for service notes with columns for ID, Date, and Service notes. The table is currently empty.

Trend

Display of burner load, flame signal and boiler temperature.



Combustion

Display of boiler temperature, actual load and output.

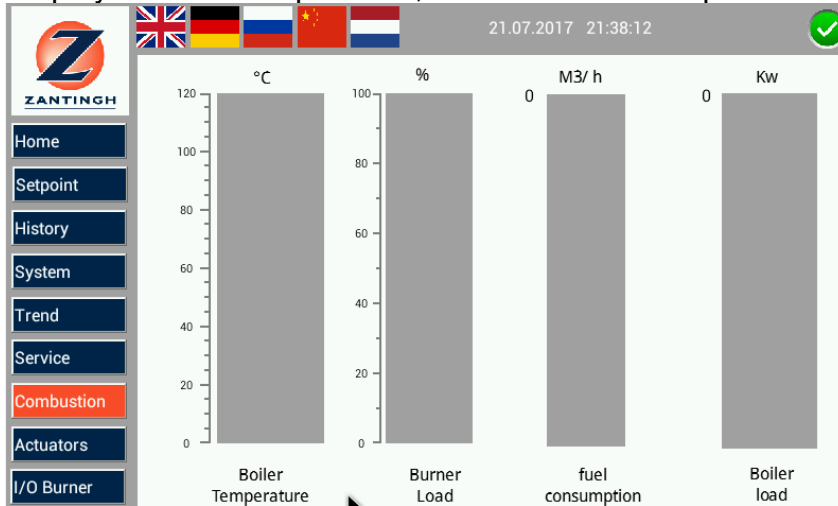

Actuators

Position of the actuators and related load in %.

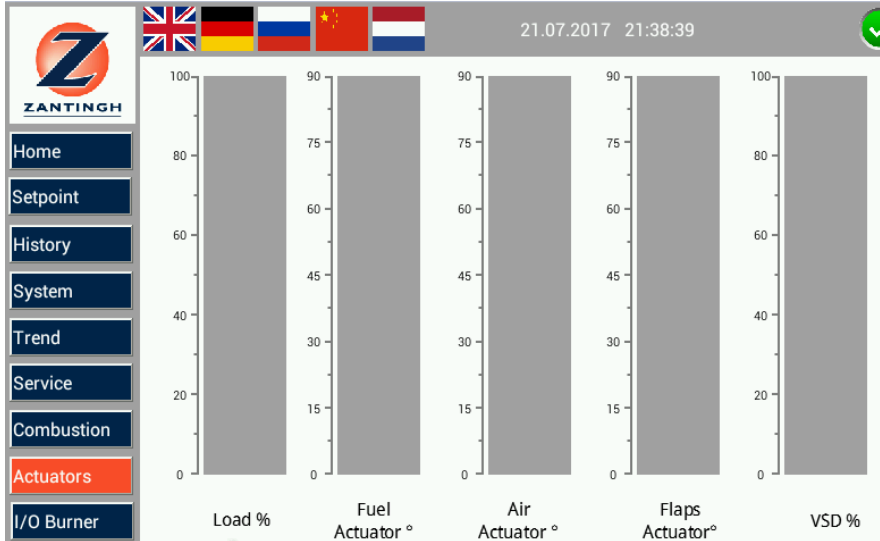

In / outputs

Display of which in- or outputs are closed or open.

Also the burner phase error code (Siemens LMV code) will be displayed.



Settings for limited maximum load

In the Home screen press on the red MAX LOAD block in the system image. Press on “Max Load Manual Preset” and then on the the blue box next to it, see image below. Now set the desired maximum load in percentages and press “Enter”.

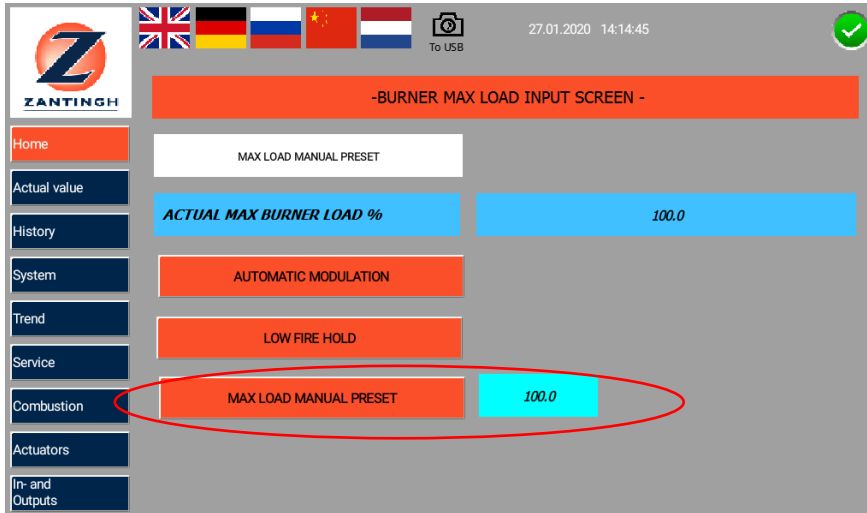

5.5 Switch from gas to oil and back (if applicable)

The burner is equipped with a gas valve and air valves for fuel air ratio control (1:7). When gas firing, the burner capacity is controlled by the stand alone modulating PID controller that is integrated in the Siemens LMV unit or by the climate computer through Fiduface.

For oil firing, the burner is equipped with a 2- or 3-stage oil combustion system (depending on the capacity) with oil valves for fuel air ratio control (1:3). The combustion capacity is controlled by the stand alone modulating PID that is integrated in the Siemens LMV unit.

From gas to oil:

1. Before switching from gas to oil firing, set the burner load switch to “LOW” and wait until the burner flame is low. Now set the main switch on the burner panel to “OFF”.
2. Check that the boiler temperature setpoint is not below 70°C to prevent oil condensation. See chapter 6 on how to change setpoint.
3. Close shut off valve A1.
4. Set the flue gas inlet valve of the condenser on bypass.
5. Check that every valve to the oil pump is open and whether the oil pump is filled with oil. The complete system has to be filled with oil without any air. If this is not the case it may cause major defects. The oil pump is not a self-suction pump.
6. Set the selector switch from “GAS” to “OIL”.
7. Set the burner load switch to “AUTO” and switch the burner on.

**WARNING:**

When not specifically stated otherwise, the burner is made for oil as emergency fuel only. After more than 24 hours on oil firing the burner system may be dirty. Reliable and clean combustion can no longer be guaranteed.

If a flame failure occurs more than 3 times during start-up, check the furnace for oil. When the boiler temperature is higher than 65 °C the oil in the furnace may gasify. At the next attempt to start, the ignition may ignite the gasified oil and may cause an **explosion**.

The annual maintenance work should include running the burner on oil!
Make sure you have enough oil on stock.

Note: installing, checking and filling the oil tank and oil piping from the oil tank to the oil pump is not within the scope of our service engineer. This is the responsibility of the user.

From oil to gas:

1. Set the main switch on the burner control panel to "OFF".
2. Close all oil valves in the oil line.
3. Set the selector switch from "OIL" to "GAS".
4. Switch the load switch to the required setting.
5. Set the flue gas inlet valve of the condenser to standard operation.
6. Open shut off valve A1.
7. Set the main switch on the burner control panel to "ON".

**WARNING:**

Before starting the system, check the furnace for oil. If the boiler temperature is higher than 65 °C the oil in the furnace may gasify. At the next attempt to start, the ignition may ignite the gasified oil and may cause an **explosion**.

Ask the burner engineer to demonstrate the switch from gas to oil and back.

6. MAINTENANCE

Never perform any maintenance or any other activity on the burner (system) without adequate knowledge and understanding of the system. When performing any activity on the system, always switch off the main switch and make sure that it cannot be switched on!

To assure the safe and proper operation of the burner, it is recommended that the burner be inspected and serviced at least once a year by a qualified service engineer.



IMPORTANT:

First set the main switch on the burner panel to “OFF” before performing any maintenance work. Lock the switch to ensure nobody can set the main switch to “ON” when performing the maintenance work. Never work on the system if the control panel is live (energized).

When switching off the main burner control panel switch also switch off the power of any connected CO₂ dosing unit control panel.

Remarks:

- The burner system is supplied according to applicable safety regulations, but it is the end user's responsibility to ensure safety through annual maintenance work on the system, according to applicable regulations.
- To ensure the good operation of the heating system, the boiler room has to be kept clean. It may not be used for storage purposes. The parts which may need maintenance work need to be accessible at all times.
- Keep the air supply grille and air extraction openings free and clean. Inadequate air ventilation can lead to hazardous situations.
- The boiler room has to be illuminated using mounted electrical lighting, to make sure that all parts of the system can be properly maintained even without daylight.
- Any water leaks have to be repaired immediately.
- If you have any doubts concerning the control or operation of the system, please contact your burner technician or supplier.

6.1 Burner service term

In optimal operating conditions and with preventive maintenance, the burner can last up to 20 years. Upon expiry of the burner service term, it is necessary to carry out a technical diagnosis and, if necessary, an overall repair/revision of the system.

The burner status is considered to be at its limit if it is technically impossible to continue using it due to non-compliance with safety requirements or a decrease in performance. The owner makes the decision whether to revise and continue using the burner, or replacing and disposing of it, based on the actual status of the system and any repair costs.

6.2 Seasonal stop

To stop the burner in the seasonal stop, proceed as follows:

1. Turn the burner main switch to "OFF".
2. Disconnect the main power supply.
3. Close the fuel/gas valve A1 of the supply line.

6.3 Burner disposal



IMPORTANT:

The use of the burner for other purposes after the expiry of the terms of use is strictly prohibited.

In case of disposal, follow the instructions according to the laws in force in your country about the "Disposal of materials".

7. BURNER FAILURE REPORT

All safety devices have a signal light on the control panel. At every lockout of a safety device the corresponding signal light will be on. To reset the system press the reset button on the switch panel door. The burner will attempt to restart.

Note: The maximum thermostat and the low water protection device may be mechanically locked. The reset button on the safety device itself should be pressed first, before resetting the whole system. If the burner does not start a failure of the CO₂-dosing unit and/or CO-detector may have been triggered.

Keep a close eye on parts which may not operate appropriately when restarting. If the same error occurs again:

- Write down the text/code which appears in the display of the AZL unit. See “Display and error messages” (separate AZL manual).
- Write down the system number, burner type and manufacturing year (refer to the label on the burner control panel).
- Contact our local service department. They will first attempt to solve the problem via the telephone call.

7.1 Troubleshooting

Gas valves/leak test

Before and during every burner start the safety valves (pos. VA1 en VA2) and pilot valve (pos. MK2) are checked for leaks.

Possible causes:

- Failure of the “leak test” can indicate that one of the safety valves or the pilot valve was not closed during standstill/start period.

Check:

- If bleed valve K1 is closed/gas-tight.
- External gas leakage visible (smell/“leak finder”/soap and water solutiony).
- Write down the diagnostic code from the burner display.

Gas pressure too low

The minimum gas pressure switch (pos. LD1) mounted before the safety valves ensures the supplied minimum gas pressure is continuously checked. If the gas supply pressure drops lower than 20% of the standard pressure (or another setpoint which is considered to be a safe setting by the authorized burner engineer), the safety device triggers a system lockout.

Check:

- If manual gas valve (A1) is fully opened.
- The gas supply pressure before the gas train, by pressing the press-button valve (pos. K2) under the manometer to read the current pressure on the manometer (pos. M). Or check the manometer on the gas supply gas train. This pressure has to be approximately the same as indicated in the contract.
- If the gas supply pressure is ok, check the gas filter (pos. F1) for dirt (close gas valve A1 manually first).

Maximum gas pressure

The maximum gas pressure switch (pos. HD), mounted on the burner gas inlet, protects the boiler against overloading. The gas pressure on the burner head is measured for this purpose. If the pressure is higher than the setpoint value the system is locked out.

Possible causes:

- Abnormal outlet pressure of pressure regulator.
- Dirty condenser.
- Abnormal gas supply pressure.

Check:

- The position of the burner control box (if applicable) where the failure occurs.
- The condensate drain of the condenser.

Motor overload

The control panel includes overload relays to protect the electromotors. In case of failure the overload relays have to be reset manually. The overload relay types included on our panels are combined thermal and max. current protection relays.

Check:

- If all three phases (L1, L2 and L3) still have normal loads.
- If all fuses are intact Replace the fuses when required (we recommend replacing all three fuses at the same time).
- Write down which overload relay triggers a lockout, if after resetting the motor makes a sound similar to an animal growl and doesn't run smoothly one phase may still not be working properly.

Air pressure too low

The air pressure is monitored using air pressure switches (pos. LD2) mounted on the burner. The pressure is checked 30 seconds after the air fan is started.

Possible causes:

- The air inlet of the air fan is blocked (plastic bag).
- The air fan is very dirty.
- The air valves are very dirty.
- The flexible measuring hose to the pressure switch is broken or blocked.
- The overload relay is locked out (see previous item).

Check:

- The air fan inlet.

Maximum temperature and/or pressure

The boiler is protected against high temperatures and/or pressure. A maximum thermostat or maximum pressostat device forms the basis for the protection. When the temperature or pressure exceeds the maximum value setting of the device the burner locks out. The maximum thermostat supplied by Zantingh is locked mechanically and has to be reset both on the thermostat itself and on the burner control panel.

Possible causes:

- Configured setpoint may be too high.
- Too little water and/or air bubbles in the boiler, fill it up and bleed it.

Low water

The water level in the boiler is monitored to protect the boiler against serious damage caused by overheating when the water level in the boiler is too low.

This safety device is supplied as one of two options:

- One or two electrodes mounted in the boiler.
- Mechanical float switch.

Possible causes:

- Water level too low (for example due to a system leak).
- Feed water pump malfunction.
- Expansion system low pressure.

Max. temp. condenser (when applicable)

This failure occurs when the water temperature in the flue gas condenser is too high.

Check:

- Condenser water flow: Check whether the circulation pump is operating properly and whether the manual shut-off valves are closed.
- That the condenser and the connected system do not have air in them.

WARNING!! Watch out for hot parts and spraying hot water in case of leaks!

Max. pressure condenser (when applicable)

The condenser is checked for contamination using a pressure switch which measures the condenser backpressure. If the backpressure measured at the switch is too high, the burner is locked out. The pressure switch is mounted on the flue gas duct between the boiler and the condenser.

Possible causes:

- Condenser is dirty.
- Flue gas valve(s) is/are not in the correct position.
- Condensate drain is blocked.

Check:

- Open the inspection cover to check for contamination.
- The position of the flue gas valves.
- The condensate drain and syphon under the condenser.

Frequency control code F

When an internal or external frequency control error is triggered the frequency control is switched off and the "F" symbol error code is displayed followed by a number including a brief description.

Under normal conditions the frequency control unit does not require maintenance work. The frequency control unit includes a cooling fan to blow the surrounding air

over the cooling body. Take care that the air openings are not blocked. If the cooling body becomes too hot the control will trigger an “F14” error.

Attention! If you contact our service department because of a failure, please write down the error code and description. Once the cause of the failure is removed the error can be reset by pressing the “reset/enter” button.

Flame failure

Flame failure is the most difficult burner system error to trace.

If the flame monitor does not locate a flame, depending on the start sequence phase, a flame failure may be triggered.

A flame failure can occur because the gas flame does not ignite. The problem can be the electric spark does not light the pilot flame or the pilot flame doesn't ignite the main flame.

The combustion may also be unstable causing the flame to go out during operation.

Because of the many potential causes it is very hard to determine why the flame failure occurs. The start sequence phase when the failure occurs may provide additional information. **Write down the error code indicated in the faults section on the display of the burner management system.**

Potential causes

No ignition spark:

- Defect ignition transformer.
- Defect or incorrectly adjusted ignition electrodes.
- Loose ignition cables.
- Spark not in the correct position (Refer to information on Earth/mass).

No pilot flame:

- Defect gas solenoid (pos. MK2).
- No combustible gas mixture, does not ignite.
- Pilot valve isn't detected by flame monitoring unit or flame signal is too low.

No main flame:

- Defect safety valve(s) (pos. VA1 and VA2).
- The air-gas ratio is not appropriate, because of which the air-gas mixture does not ignite, or even goes out during operation.
- Main flame is not detected by the flame monitoring unit because the flame is too low.

Flame failure before gas valves have opened:

- Defect UV scanner.
Inappropriate lighting, for example, through sight glass.

8. WARRANTY CONDITIONS

Zantingh B.V. guarantees this Zantingh product for the installer under the following conditions. The installer guarantees this product to the user under the same conditions which are provided below.

1. The period of guarantee is valid as from the day of delivery on location.
The guarantee has a fixed period of 12 months, based on the agreed sales price.
2. A recognized installer should install the system according to the applicable general and local standards and regulations based on the assembly and operation instructions provided by Zantingh.
3. The system may not be moved from the original location.
4. The guarantee becomes null and void if and when:
 - Defects of the system are not reported in writing to the installer and/or Zantingh B.V. immediately after having been discovered or these could reasonably be expected to have been discovered.
 - Defects are caused by errors, improper use or neglect by the installer and/or the user who has placed the order or his/her legal successor or caused by external causes.
 - During the period of guarantee a third party is requested to or implements changes to the system or when the user has done so without prior written consent by the authorized installer and/or Zantingh B.V.
 - During the period of guarantee the expert inspections and/or maintenance work are periodically not performed even though the equipment requires it.
 - Corrosion has been caused by polluted flue gas, to be determined by Zantingh B.V.
 - If after research is carried out, one or more of the above conditions were not taken into account and are the reason for any guarantee claim, the costs for the required research by Zantingh B.V. or third parties will be charged to the user.
5. The initial request based on the guarantee obligations described in this article should be submitted in writing to the installer within five working days after the error or defect has been observed or could reasonably have been observed.
6. The stipulations included in our general guarantee, sales and payment conditions, issued by the ORGALIME S 2012 “General conditions for the supply of mechanical, electrical and electronic products” are also applicable. Zantingh B.V. will not be liable for any consequential damage to the Zantingh system other than a defect covered by the guarantee as described above. Moreover, Zantingh B.V. will not be liable for any damage to income and/or loss of profit to the user of any nature whatsoever.
7. Any costs incurred by assembly or disassembly, travelling or accommodation expenses, constructional costs and such required to execute the terms of the guarantee are excluded from the terms of the guarantee.

Any dispute between Zantingh B.V. and the buyer regarding a claim based on the guarantee will be resolved by an expert and independent authority if so desired. The parties agree to abide by the binding decision of said authority.

Imprint

All rights reserved, including the rights to the translations. Nothing from this issue may be copied, stored in an automatic data file or made public in any way or by any means, be it electronically, mechanically, photocopy or otherwise, without prior written consent from Zantingh B.V. Reprinting the document or any excerpt thereof, is forbidden. Changes, errors and misprints reserved. These assembly and operation instructions comply with the technical requirements at the time of printing. We reserve the right to implement technical and design changes.

Netherlands

Zantingh B.V.

Aarbergerweg 9, 1435 CA RIJSENHOUT
Postbus 255, 1430 AG AALSMEER
Netherlands
Phone (+31) (0)297 - 219 100
E-mail info@zantingh.com
Website www.zantingh.com

France

Zantingh France SARL

95, rue F. de Lesseps
F-44150 Ancenis
France
Phone (+33) (0)240 83 94 30
E-mail info@zantingh.fr
Website www.zantingh.com

Mexico

Zantingh México S.A. de C.V.

Parque Industrial Benito Juárez
Acceso III no.14
76120 Querétaro
Mexico
Phone (+52) 422 209 50 60
E-Mail info@zantingh.mx
Website www.zantingh.com